Safety Messages

Your safety and the safety of others is very important. We have provided important safety messages in this manual and on the HRC CBR1000RR. Please read these messages carefully.

A safety message alerts you to potential hazards that could hurt you or others. Each safety message is preceded by a safety alert symbol  and one of three words, **DANGER**, **WARNING**, or **CAUTION**.

These mean:

 **DANGER**

You **WILL** be **KILLED** or **SERIOUSLY HURT** if you don't follow instructions.

 **WARNING**

You **CAN** be **KILLED** or **SERIOUSLY HURT** if you don't follow instructions.

 **CAUTION**

You **CAN** be **HURT** if you don't follow instructions.

Each message tells you what the hazard is, what can happen and what you can do to avoid or reduce injury.

Damage Prevention Messages

You will also see other important messages that are preceded by the word **NOTICE**.

This word means:

NOTICE

Your HRC CBR1000RR or other property can be damaged if you don't follow instructions.

The purpose of these messages is to help prevent damage to your HRC CBR1000RR, other property, or the environment.

HRC CBR1000RR Racing Kit

Set-up Manual/Parts List

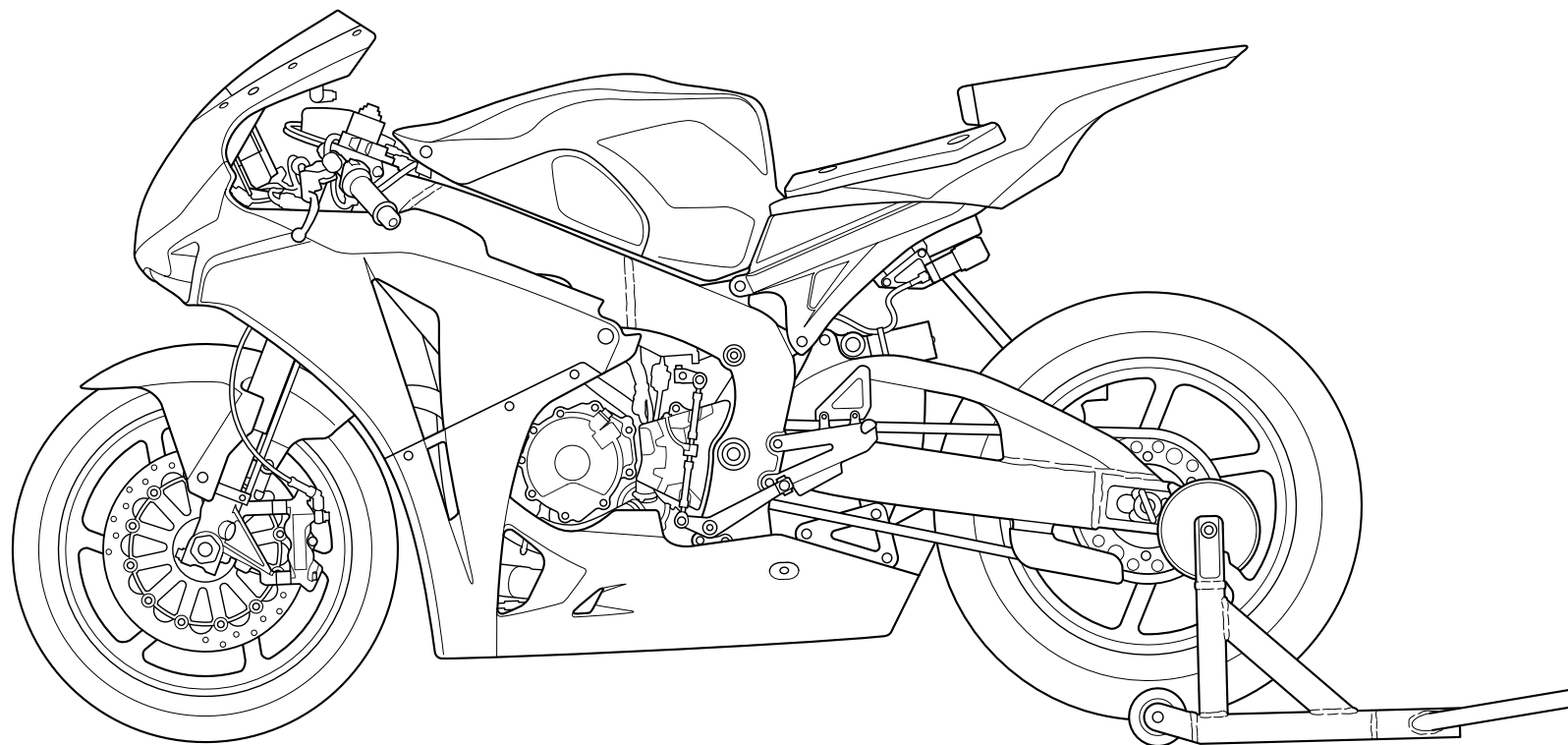

All information in this publication is based on the latest product information available at the time of approval for printing.
Honda Racing Corporation reserves the right to make changes at any time without notice and without incurring any obligation.
No part of this publication may be reproduced without written permission.

Important Information

- This kit is sold as is without warranty, and the entire risk as to quality and performance is with the buyer.
 - This kit is designed and manufactured to enhance the performance of the CBR1000RR, and as is stated in the CBR1000RR owner's manual, should be used only in an organized racing or competitive event upon a closed course which is conducted under the auspices of a recognized sanctioning body or by permit issued by the local governmental authority having jurisdiction.
 - This kit is not suitable for use with any other parts.
 - Refer to section 2 for function of the handlebar switches.
-

Contents

1. Service Information

General Information	1-1
Service Data	1-1
Torque Values	1-2
Lubrication & Seal Points	1-6
Maintenance Schedule	1-8
Inspection/Replacement Parts	1-10
Removal/Replacement Parts	1-12
Cable & Harness Routing	1-13
Wiring Diagram	1-14

2. Racing Kit

Replacement Parts	2-1
Modifying the Cylinder Head Ports	2-2
Adjusting the Compression Ratio	2-3
Inlet Valve Seat Maintenance	2-5
Modifying Crankcase	2-6
Oil Pressure Relief Valve Replacement	2-10
Cam Sprocket Kit Installation	2-11
Cylinder Head Bolt Tightening	2-13
ACG Set Installation	2-14
Transmission Set Installation	2-16
Optional Transmission Gears	2-17
Clutch Kit Installation	2-19
Main Journal Bolt Tightening	2-20
Connecting Rod Bolt Tightening	2-20
Balancer Backlash Adjustment	2-21
Engine Hanger Tightening Sequence	2-22
Wire Lock	2-24
Quick Shift Kit Installation	2-25
Secondary Air Supply System Removal	2-26
Thermostat Replacement	2-27
Air Bleed Hose Removal	2-27
Variable Air Intake Valve Removal	2-28
Oil Cooler Kit Installation	2-29
Radiator Kit Installation	2-30
Hi Throttle Set/Engine Stop Switch Installation	2-31
Breather Case Installation	2-32
Air Funnel Replacement	2-33
Steering Damper Replacement	2-34
Steering Stem Modifying	2-35

Throttle Body Replacement	2-35
Fuel Feed Hose Removal/Installation	2-36
Fuel Pump Kit Installation	2-37
Bank Angle Sensor Installation	2-40
Seat Rail Replacement/Battery Tray Installation	2-41
Exhaust Pipe/Muffler Replacement	2-42
Drive Chain Guard Installation	2-43
Fork Spring Replacement	2-44
Front Suspension Setting	2-47
Rear Shock Absorber Spring	2-47
Rear Suspension Setting	2-48
Optional Front Wheel	2-49
Optional Rear Wheel	2-56
Front Wheel Speed Sensor Installation	2-63
Combination Meter Function	2-64
Left Handlebar Switch Function	2-66
Mode Switch	2-66

Memo

1. Service Information

General Information

- This Set-up Manual contains information for the CBR1000RR Racing Kit.
- Refer to the Shop Manual for service procedures and data not included in this manual.

Service Data

Comparison between standard CBR1000RR and Racing kit installed CBR1000RR.

Item		2008 Standard	2008 Racing Kit (Super Bike Kit)	
Engine	Type	Water cooled 4-stroke DOHC 16 valve	←	
	Cylinder arrangement	27.6° inclined inline four	←	
	Bore and stroke	76.0 x 55.1 mm (2.99 x 2.17 in)	←	
	Displacement	999 cm ³ (60.94 cu-in)	←	
	Compression ratio	12.3 : 1	13.1 : 1	
	Cylinder head gasket thickness	t0.6	←	
	Valve clearance	IN	0.16 ± 0.03 mm (0.006 ± 0.001 in)	0.20 ± 0.02 mm (0.008 ± 0.001 in)
		EX	0.30 ± 0.03 mm (0.012 ± 0.001 in)	0.30 ± 0.02 mm (0.012 ± 0.001 in)
	Valve train	DOHC, chain driven	←	
	Valve timing	Intake	opens	21° BTDC
			closes	43° ABDC
		Exhaust	opens	41° BBDC
			closes	14° ATDC
	Valve lift	Intake	9.3 mm	←
Exhaust		8.4 mm	←	
Fuel delivery system	PGM-DSFI, ø46	←		
Electrical	Spark plug	NGK: IMR9E-9HES, DENSO: VUH27ES	NGK: R0459A-10	

NOTICE

- Honda's testing has shown that the optimum overall performance of the Honda CBR1000RR engine power up kit can be obtained by using an appropriate exhaust system.
- No testing was done to verify serviceability or overall quality. Honda makes no claim and assumes no responsibility as to the reliability or quality of these components.

Use unleaded premium gasoline (research octane number 100)

Service Information

Torque Values

Standard Torque

Item	Thread/ pitch	Torque N·m (kgf·m, lbf·ft)	Remarks
M5 bolt and nut	M5 x 0.8	4.9 (0.5, 3.6)	Apply oil
M6 bolt and nut	M6 x 1.0	10 (1.0, 7)	Apply oil
M8 bolt and nut	M8 x 1.25	22 (2.2, 16)	Apply oil
M10 bolt and nut	M10 x 1.25	34 (3.5, 25)	Apply oil
M12 bolt and nut	M12 x 1.25	54 (5.5, 40)	Apply oil
M5 screw	M5 x 0.8	4 (0.4, 2.9)	
M6 screw, SH bolt	M6 x 1.0	9 (0.9, 6.5)	Apply oil
M6 flange bolt and nut	M6 x 1.0	12 (1.2, 9)	Included NSHF bolt; apply oil
M8 flange bolt and nut	M8 x 1.25	26 (2.7, 20)	Apply oil
M10 flange bolt and nut	M10 x 1.25	39 (4.0, 29)	Apply oil

NOTICE

- Use Honda Ultra E1 oil on the specified bolts and nuts. Inaccurate torque or cross-threading may occur if the specified oil is not used.
- Check the crankcase cover bolt seating surfaces before tightening the cover bolts. If the crankcase cover painting peels off, remove paint off from the bolt seating surfaces, then tighten the bolts.

Engine

Item	Thread/ pitch	Torque N·m (kgf·m, lbf·ft)	Remarks
Main journal bolt	M9 x 1.25	20 (2.0, 14) + 60° + 60°	Apply oil after removing anti-rust additive; retightening limit: 5 times When replacing new bolts: temporarily tighten the bolts 1 time.
Crankcase bolt	M10 x 1.25	39 (4.0, 29)	Apply oil
	M8 x 1.25	24 (2.5, 18)	Apply oil
	M7 x 1.0	18 (1.8, 13)	Apply oil
Main oil gallery sealing taper plug	PT1/8	12 (1.2, 9)	Apply Three bond 1207B
Oil drain bolt	M12 x 1.5	29 (3.0, 22)	Apply oil, wire lock
Alternator cover sealing bolt	M14 X 1.5	29 (3.0, 22)	Apply oil, wire lock
Timing hole cap	M45 x 1.5	18 (1.8, 13)	Apply grease, wire lock
Left crankcase rear cover bolt	M6 x 1.0	12 (1.2, 9)	Apply oil
Cylinder head tightening nut	M9 x 1.25	25 (2.5, 18) + 67.5° + 67.5°	Apply oil to the nut, washer and stud bolt threads When replacing the cylinder head, stud bolt, washer and/or nut: temporarily tighten the nuts 1 time.
Cylinder head/cylinder mounting bolt	M6 x 1.0	12 (1.2, 9)	Apply oil
Camshaft holder bolt	M6 x 1.0	12 (1.2, 9)	Apply oil
Cylinder head cover bolt	M6 x 1.0	9.8 (1.0, 7)	Apply oil
Breather plate bolt	M6 x 1.0	12 (1.2, 9)	Apply LOCKTITE 271
PAIR reed valve cover bolt	M6 x 1.0	12 (1.2, 9)	Apply LOCKTITE 271

Item		Thread/ pitch	Torque N•m (kgf•m, lbf•ft)	Remarks
Connecting rod bolt		M8 x 0.75	27.5 (2.8, 20) + 45° + 45°	New bolt: apply oil, temporarily tighten 1 time
			21.6 (2.2, 16) + 45° + 45°	Checking oil clearance: apply oil; retightening limit: 5 times
Starter clutch outer bolt		M10 x 1.25	20 (2.0, 14) + 60°	Apply oil, new bolt: temporarily tighten 1 time Retightening limit: 10 times When using a new bolt, replace a washer with a new one
Flywheel bolt	Standard	M10 x 1.25	103 (10.5, 76)	Apply oil; <ul style="list-style-type: none"> When using the new crankshaft or flywheel: Temporarily tighten 2 times with 103 N•m (10.5 kgf•m, 76 lbf•ft). Temporarily tighten 1 time when flywheel reinstallation We recommend that the racing kit flywheel bolt (90003-NL9-000) be used whenever the standard flywheel is installed (page 2-14). When using the racing kit flywheel bolt, follow the racing kit tightening method and torque value (see below).
	Racing kit	M10 x 1.25	15 (1.5, 11) + 60°	Apply oil; <ul style="list-style-type: none"> Temporarily tighten 3 times with 135 N•m (13.8 kgf•m, 100 lbf•ft). After tightening flywheel bolt with 15 N•m (1.5 kgf•m, 11 lbf•ft) + 60°, check the tightening torque is more than 128 N•m (13.0 kgf•m, 94 lbf•ft). Service limit: Tighten it 5 times to the specified torque When using a new bolt, replace a washer with new one
Cam sprocket bolt	Standard	M7 x 1.0	20 (2.0, 14)	Apply oil
	Racing kit	M7 x 1.0	22 (2.2, 16)	Apply oil
Camshaft position sensor rotor bolt		M6 x 1.0	12 (1.2, 9)	Apply oil
Cam chain tensioner A bolt		M6 x 1.0	12 (1.2, 9)	Apply oil
Cam chain tensioner B bolt		M24 x 1.5	74 (7.5, 55)	Apply oil
Cam chain guide bolt		M6 x 1.0	12 (1.2, 9)	Apply oil
Cam chain tensioner lifter bolt		M6 x 1.0	12 (1.2, 9)	Apply oil
Oil pump assembly bolt		M6 x 1.0	12 (1.2, 9)	CT bolt
Oil pump driven sprocket bolt		M6 x 1.0	15 (1.5, 11)	Apply oil
Oil pipe bolt		M6 x 1.0	12 (1.2, 9)	Apply oil
Oil jet pipe bolt (right and left)		M6 x 1.0	12 (1.2, 9)	Apply oil
Oil pump chain guide bolt		M6 x 1.0	12 (1.2, 9)	Apply oil
Oil cooler bolt		M20 X 1.5	59 (6.0, 44)	Apply oil, wire lock
Oil filter cartridge		M20 x 1.5	26 (2.7, 20)	Apply oil, wire lock
Throttle body insulator bolt		M6 x 1.0	12 (1.2, 9)	Apply oil

Service Information

Item	Thread/ pitch	Torque N·m (kgf·m, lbf·ft)	Remarks
Air funnel bolt	M5 X 0.8	7 (0.7, 5.2)	Wire lock
Thermostat cover bolt	M6 x 1.0	12 (1.2, 9)	CT bolt
ECT sensor	M12 x 1.5	23 (2.3, 17)	
Water joint bolt	M6 x 1.0	12 (1.2, 9)	Apply oil
Water pump cover bolt	M6 x 1.0	12 (1.2, 9)	CT bolt
Water pump impeller	M6 x 1.0	12 (1.2, 9)	Left hand thread
Clutch center lock nut	M25 x 1.0	128 (13.0, 94)	Apply oil
Transmission bearing set plate bolt	M6 x 1.0	12 (1.2, 9)	Apply LOCKTITE 271
Drive sprocket bolt	M10 x 1.25	54 (5.5, 40)	Wire lock
Shift drum center bolt	M8 x 1.25	23 (2.3, 17)	Apply LOCKTITE 271
Shift drum stopper arm bolt	M6 x 1.0	12 (1.2, 9)	Apply LOCKTITE 271
Shift return spring pin	M8 x 1.25	23 (2.3, 17)	Apply oil
Shift drum bearing set plate bolt	M6 x 1.0	12 (1.2, 9)	Apply LOCKTITE 271
Shift drum stopper plate bolt	M6 x 1.0	12 (1.2, 9)	Apply LOCKTITE 271
Alternator stator mounting bolt	M6 x 1.0	12 (1.2, 9)	Apply LOCKTITE 271
Starter motor terminal nut	M6 x 1.0	12 (1.2, 9)	Apply oil
Neutral switch	M10 x 1.25	12 (1.2, 9)	
Spark plug	M10 x 1.0	14 (1.4, 11)	
Cylinder stud bolt	M9 x 1.25	4.9 (0.5, 3.6) minimum	After tighten them to the specified torque, adjust bolt height (see illustration below)
Insulator band	M5 X 0.8	-	Band width: 7 ± 1 mm
Water hose band	-	-	Tightening width: 0 to 0.2 mm on each side

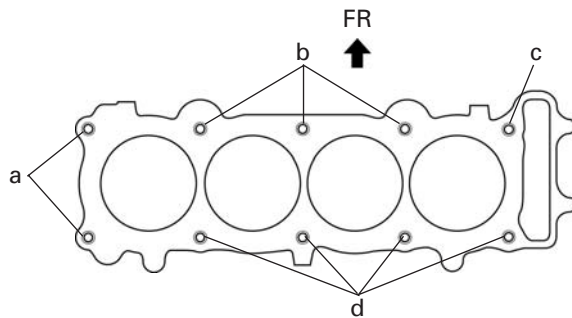

	Part Number	Height from the crankcase
a	90033-MFL-003	135.5 ± 0.5 mm
b	90033-MFL-003	132.0 ± 0.5 mm
c	90033-MFL-003	137.5 ± 0.5 mm
d	90032-MFL-003	132.0 ± 0.5 mm

Frame

Item	Thread/ pitch	Torque N•m (kgf•m, lbf•ft)	Remarks
Fuel tank cap socket bolt	M4 x 0.7	4.9 (0.5, 3.6)	
Swingarm pivot nut	M22 x 1.5	98 (10.0, 72)	Apply molybdenum grease to the threads
Rear wheel bearing retainer	M56 x 1.0	98 (10.0, 72)	Apply LOCKTITE 271
Rear brake disc bolt	M6 x 1.0	16 (1.6, 12)	Apply LOCKTITE 271
Rear axle	M18 x 1.5	98 (10.0, 72)	Apply molybdenum grease to the threads
Final driven sprocket nut	M8 x 1.25	34 (3.5, 25)	Apply oil to the threads
Rear brake bleeder screw	M8 x 1.25	7.8 (0.8, 5.8)	
Rear brake caliper mounting bolt	M7 x 1.0	17 (1.7, 12)	Apply molybdenum grease to the threads
Front wheel axle	M18 x 1.5	59 (6.0, 43)	Apply molybdenum grease to the threads
Front wheel bearing retainer	M46 x 1.25	39 (4.0, 29)	Apply molybdenum grease to the threads, stake
Front axle side nut	M28 x 1.0	78 (8.0, 58)	Apply molybdenum grease to the threads
Front brake caliper mounting bolt	M10 x 1.25	39 (4.0, 29)	Apply molybdenum grease to the threads
Front brake caliper oil bolt	M10 x 1.25	34 (3.5, 25)	
Front axle holder bolt	M8 x 1.25	22 (2.2, 16)	Apply molybdenum grease to the threads
Rear shock absorber upper bolt	M10 x 1.25	34 (3.5, 25)	Apply molybdenum grease to the threads
Shock arm/shock link bolt/nut	M10 x 1.25	34 (3.5, 25)	Apply molybdenum grease to the threads
Steering stem top threads:			
Showa special fork:	M26 x 1.0	9.8 (1.0, 7)	Adjusting range: 0.6 to 1.5 kgf•m
Standard fork:	M26 x 1.0	26 (2.7, 20)	See shop manual for tightening procedure
Steering stem nut:			
Showa special fork:	M24 x 1.0	98 (10.0, 72)	Apply molybdenum grease to the threads Adjusting range: 8 to 13 kgf•m
Standard fork:	M24 x 1.0	103 (10.5, 76)	See shop manual for tightening procedure
Top bridge/bottom bridge pinch bolt	M8 x 1.25	22 (2.2, 16)	Apply molybdenum grease to the threads
Front engine hanger bolt	M12 x 1.25	59 (6.0, 43)	Apply molybdenum grease to the threads
Rear upper engine hanger nut	M12 x 1.25	49 (5.0, 36)	Apply molybdenum grease to the threads
Rear lower engine hanger nut	M12 x 1.25	59 (6.0, 43)	Apply molybdenum grease to the threads
Engine hanger adjusting bolt	M20 x 1.5	9.8 (1.0, 7)	Apply molybdenum grease to the threads
Engine hanger adjusting bolt lock nut	M20 x 1.5	59 (6.0, 43)	Apply molybdenum grease to the threads

Service Information

Lubrication & Seal Points

Engine

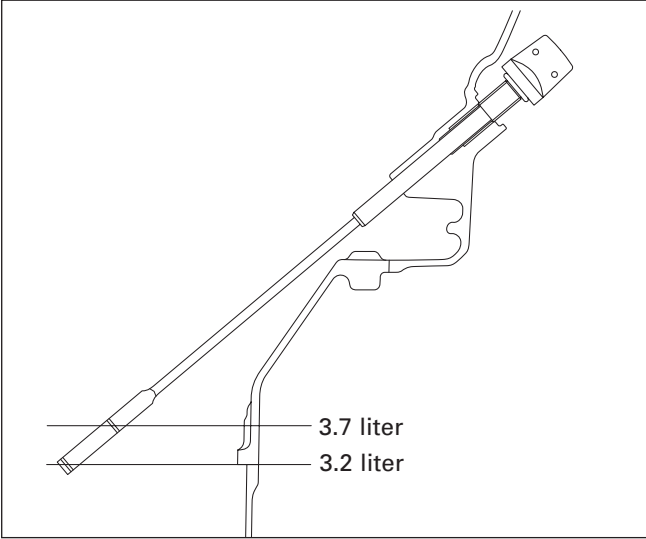
Item	Material	Remarks
Piston pin outer surface Connecting rod small end inner surface Clutch lifter piece sliding surface IN/EX valve stem sliding surface Clutch outer guide sliding surface Oil pump drive sprocket collar sliding surface M3/4, C5, C6 gear shift fork groove Starter reduction shaft pivot sliding surface Starter idle gear shaft sliding surface Piston ring grooves Piston ring surface Oil strainer packing surface Clutch disc surface Starter one-way clutch surface Each gear teeth Each ball bearing and needle bearing Each O-ring Other rotating and sliding surface	Elf XT3818 oil or Elf HTX3818	

Item	Material	Remarks
Main journal bearing sliding surface Connecting rod bearing Crankshaft thrust surface Camshaft sliding surface and thrust surface Valve lifter sliding surface	Molybdenum disulfide oil (a mixture of 1/2 Elf XT3818 oil or Elf HTX3818 and 1/2 of molybdenum disulfide grease)	Do not apply more than necessary Do not apply more than necessary
Timing hole cap threads Each oil seal lips Balancer damper rubber contact surface	Multi-purpose grease	
Crankcase mating surface Crankcase/cover mating surface Oil pan mating surface	Three bond 1207B	

Frame

Item	Material	Remarks
Rear wheel damper rubber-to-driven flange contact area Swingarm pivot dust seal lips/needle bearing Shock absorber pivot dust seal lips/needle bearing Shock link dust seal lips/needle bearing Steering stem bearing	Multi-purpose grease	
Front axle bolt threads and seating surface Rear axle bolt threads and seating surface	Molybdenum grease	UN-LOCK (manufactured by NCH) for shaft portion
Fuel pump connector	Silicone grease	
Throttle cable sliding surface Throttle pipe inner surface	CRC	
Handle grip inner surface	Honda Bond A	
Fork inside Fork oil seal lip	Fork fluid	

Service Information

Maintenance Schedule

Perform pre-ride Inspection at each scheduled maintenance period.

I: Inspect and clean, Adjust, Lubricate or Replacement if necessary. C: Clean, R: Replace, L: Lubricate.

Item	Frequency	Each race or about 2.5 hours	Remarks
Fuel Line		I	
Throttle Operation		I	
Spark Plug		I	
Valve Clearance		I	
Engine Oil		R	
Engine Oil Filter		R	
Intake Valves		I	R: every 3,000 km (1,850 mi)
Exhaust Valves		I	R: every 6,000 km (3,700 mi)
Valve Lifter		I	R: every 6,000 km (3,700 mi)
Valve Springs		I	R: every 6,000 km (3,700 mi)
Pistons		I	R: every 6,000 km (3,700 mi)
Piston rings		I	R: every 6,000 km (3,700 mi)
Crankpin Bearings		I	R: every 6,000 km (3,700 mi)
Main journal bearings		I	R: every 3,000 km (1,850 mi)
Cylinder Head		I	R: every 6,000 km (3,700 mi) When replacing the intake valve, maintain the valve seat
Camshaft		I	
Cylinder Sleeve		I	
Flywheel bolt		I	Every 1,500 km (930 mi); Check tightening torque: more than 128 N•m (13.0 kgf•m, 94 lbf•ft)
Radiator Coolant		I	
Cooling System		I	
Drive Chain		I, L	
Drive Chain Slider		I	
Drive/Driven Sprocket		I	
Brake Fluid		I	R: every 3 races, replace after riding in rain
Brake Pad Wear		I	
Brake System		I	
Clutch System		I	R: every race (clutch discs, plates and judder spring)
Exhaust Pipe/Muffler		I	

Item	Frequency	Each race or about 2.5 hours	Remarks
Suspension		I	
Nuts, Bolts, Fasteners		I	
Oil Catch Tank		I	Every race: drain oil from the catch tank
Wheels And Tires		I	R: every 2 years (magnesium wheel)
Steering Head Bearings		I	
Camshaft Position Sensor Connector		I	
Ignition Coil Cap		I	Check that the coil caps installed properly

Check for other parts not listed above for wear or damage. Replace any faulty parts as necessary.

Service Information

Inspection/Replacement Parts

Parts Requiring Periodic Inspection/Replacement

Item	Inspection Interval	Replacement Interval	Cause
Engine			
Crankcase	Every 1,500 km (930 mi)	Every 6,000 km (3,700 mi)	Crack
Cylinder	Every 1,500 km (930 mi)	Every 6,000 km (3,700 mi)	Sleeve wear or damage
Cylinder head	Every 1,500 km (930 mi)	Every 6,000 km (3,700 mi)	Valve seat, cam journal, valve lifter bore wear or damage (when replacing the valve, maintain the valve seat)
Crankshaft	Every 1,500 km (930 mi)	Every 3,000 km (1,850 mi)	Gear wear, crankpin/main journal wear or damage
Crankshaft bearing	Every 1,500 km (930 mi)	Every 3,000 km (1,850 mi)	Wear or damage
Connecting rod	Every 1,500 km (930 mi)	Every 6,000 km (3,700 mi)	Small end wear or damage
Connecting rod bearing	Every 1,500 km (930 mi)	Replace with connecting rod	Wear or damage
Piston	Every 1,500 km (930 mi)	Every 6,000 km (3,700 mi)	Skirt and piston land wear or damage
Piston ring	Every 1,500 km (930 mi)	Every 6,000 km (3,700 mi)	Wear or damage
Piston pin	Every 1,500 km (930 mi)	Every 6,000 km (3,700 mi)	Wear or damage
Balancer weight	Every 1,500 km (930 mi)	Every 6,000 km (3,700 mi)	Bearing contact face wear
Balancer shaft	Every 1,500 km (930 mi)	Every 6,000 km (3,700 mi)	Bearing contact face wear
Balancer bearing	Every 1,500 km (930 mi)	Every 6,000 km (3,700 mi)	Needle bearing wear
Valve spring/lifter/retainer/seat	Every 1,500 km (930 mi)	Every 6,000 km (3,700 mi)	Wear or deformation
IN valve	Every 1,000 km (620 mi)	Every 3,000 km (1,850 mi)	Valve seat warpage, When replacing the valve, maintain the cylinder head valve seat
EX valve	Every 1,500 km (930 mi)	Every 6,000 km (3,700 mi)	Valve seat warpage
Cam chain	Every 1,500 km (930 mi)	Every 6,000 km (3,700 mi)	Stick
Cam sprocket	Every 1,500 km (930 mi)	Every 6,000 km (3,700 mi)	Wear or damage
Cam chain tensioner/guide A, B/lifter	Every 1,500 km (930 mi)	Every 6,000 km (3,700 mi)	Wear or damage
Oil pump	Every 1,500 km (930 mi)	Every 6,000 km (3,700 mi)	Wear or damage
Oil pump chain/guide	Every 1,500 km (930 mi)	Every 6,000 km (3,700 mi)	Stick or wear
Oil pump drive/driven sprocket	Every 1,500 km (930 mi)	Every 6,000 km (3,700 mi)	Wear or damage
Oil cooler	Every 1,500 km (930 mi)	Every 6,000 km (3,700 mi)	Damage
Water pump	Every 1,500 km (930 mi)	Every 6,000 km (3,700 mi)	Crack
Water hose	Every 1,500 km (930 mi)	Every 6,000 km (3,700 mi)	Damage
Clutch outer	Every 1,500 km (930 mi)	Every 6,000 km (3,700 mi)	Gear wear, wear by the disc
Clutch center/pressure plate/spring	Every 1,500 km (930 mi)	Every 6,000 km (3,700 mi)	Wear by the disc, plate and cam
Clutch disc/plate/judder spring	–	Every race	Wear or burn (replace the discs/plates and judder spring as a set)

Item	Inspection Interval	Replacement Interval	Cause
Clutch lifter pin and arm	Every 1,500 km (930 mi)	Every 6,000 km (3,700 mi)	Wear or damage
Transmission gear/shaft/collar	Every 1,500 km (930 mi)	Every 6,000 km (3,700 mi)	Wear or damage
Countershaft bearing (right side)	Every 1,500 km (930 mi)	Every 6,000 km (3,700 mi)	Pin damage or lack of needle
Gearshift spindle	Every 1,500 km (930 mi)	Every 6,000 km (3,700 mi)	Needle bearing wear
Shift fork/shaft	Every 1,500 km (930 mi)	Every 6,000 km (3,700 mi)	Wear
Starter bearing	Every 1,500 km (930 mi)	Every 6,000 km (3,700 mi)	Wear or damage
Starter clutch outer bolt	Every 1,500 km (930 mi)	Every 6,000 km (3,700 mi)	or tighten it 10 times to the specified sequence; 20 N•m (2.0 kgf•m, 15 lbf•ft) +60° at inspection: retighten with 93 N•m (9.5 kgf•m, 69 lbf•ft)
Spark plug	Every 1,500 km (930 mi)	Every 6,000 km (3,700 mi)	Wear at side face of the center electrodes
Camshaft position sensor	Every 1,500 km (930 mi)	Every 6,000 km (3,700 mi)	Damage
Flywheel bolt	Every 1,500 km (930 mi)	Every 6,000 km (3,700 mi)	or tighten it 5 times to the specified sequence; 15 N•m (1.5 kgf•m, 11 lbf•ft) +60° at inspection: retighten with 128 N•m (13.0 kgf•m, 94 lbf•ft)
Stator, crankshaft position sensor	Every 1,500 km (930 mi)	Every 6,000 km (3,700 mi)	Damage
Flywheel rotor	Every 1,500 km (930 mi)	Every 6,000 km (3,700 mi)	Damage
Ignition coil cap	Every 1,500 km (930 mi)	Every 6,000 km (3,700 mi)	Damage Check that the coil caps installed properly

Check for other parts not listed above for wear or damage. Replace any faulty parts as necessary.

Removal/Replacement Parts

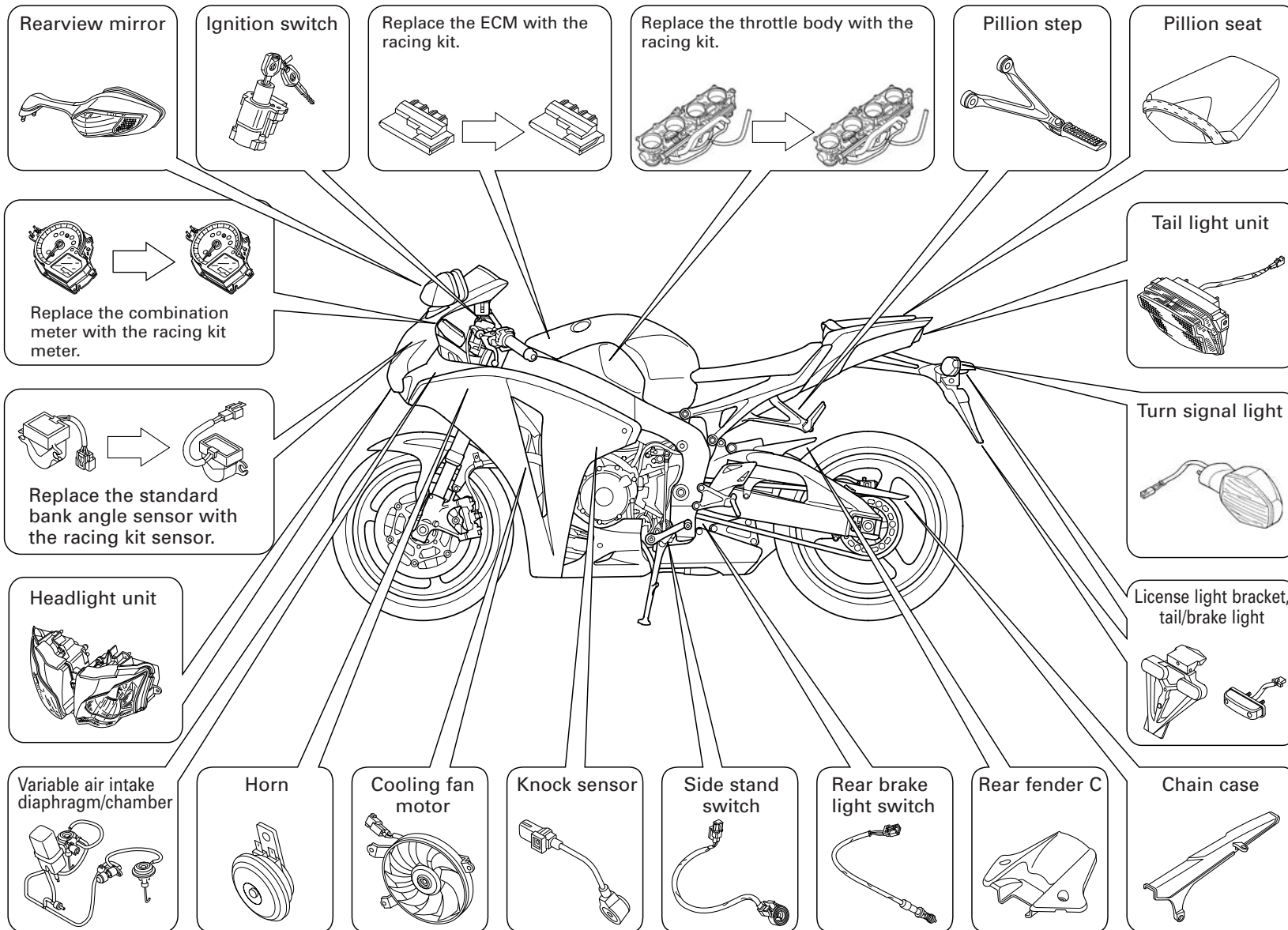

Cable & Harness Routing

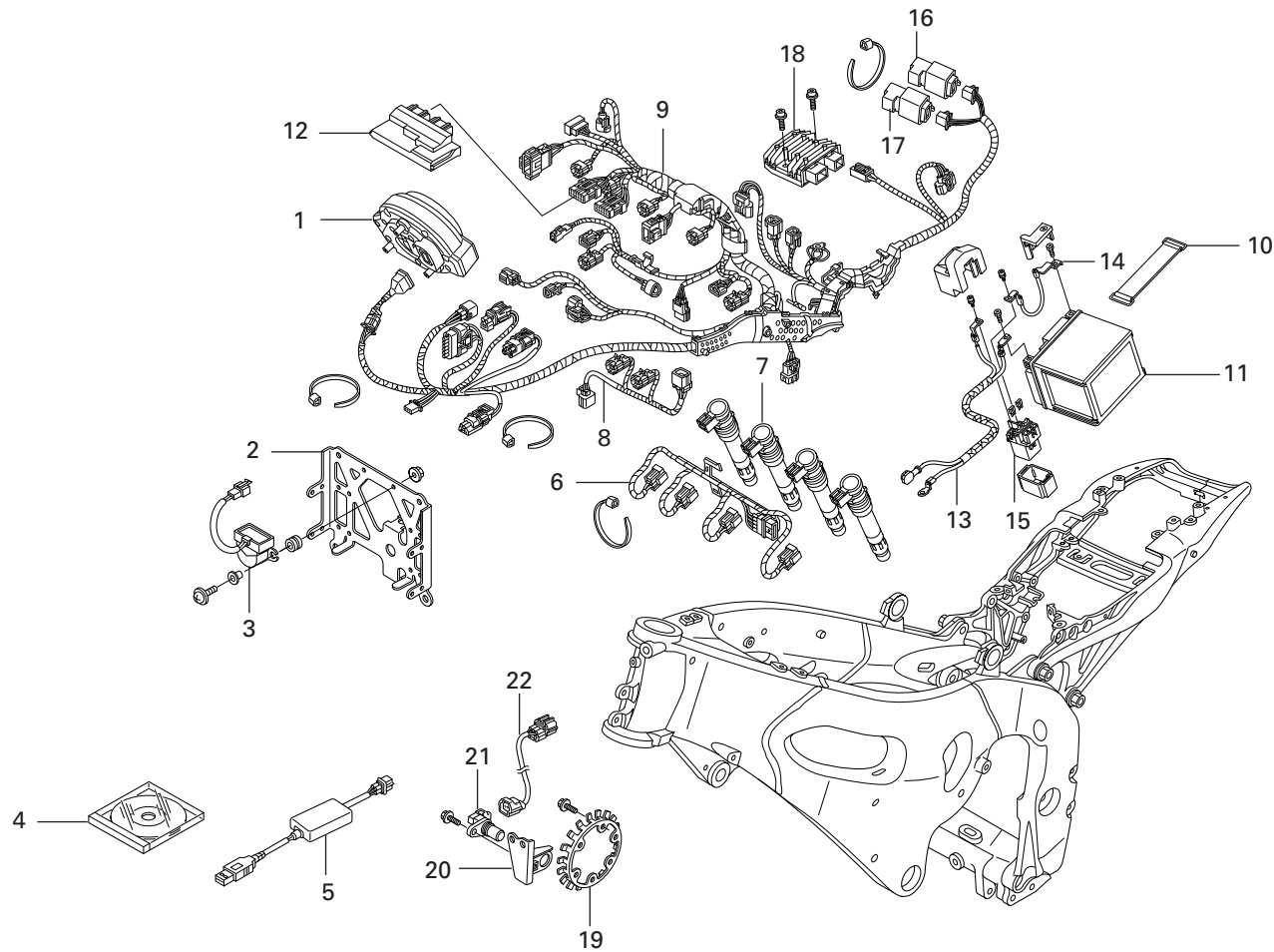

No.	Item	No.	Item	No.	Item	No.	Item
1	Combination meter	7	Coil, cap & ignition	13	Cable, starter & earth	19	Pulser, front wheel
2	Bracket, bank angle sensor	8	Sub harness, throttle	14	Cable, starter battery	20	Stay, VFW sensor
3	Sensor assy., bank angle	9	Harness, wire	15	Switch assy., starter magnetic	21	Speed sensor, final gear
4	CD-ROM, PGM-FI/IGN	10	Band, battery	16	Relay, engine stop	22	Sub-cord, speed sensor
5	Unit assy., serial I/F	11	Battery	17	Relay, fuel pump		
6	Sub harness, IGN	12	Unit, PGM-FI	18	Rectifier assembly, regulator		

Service Information

Wiring Diagram

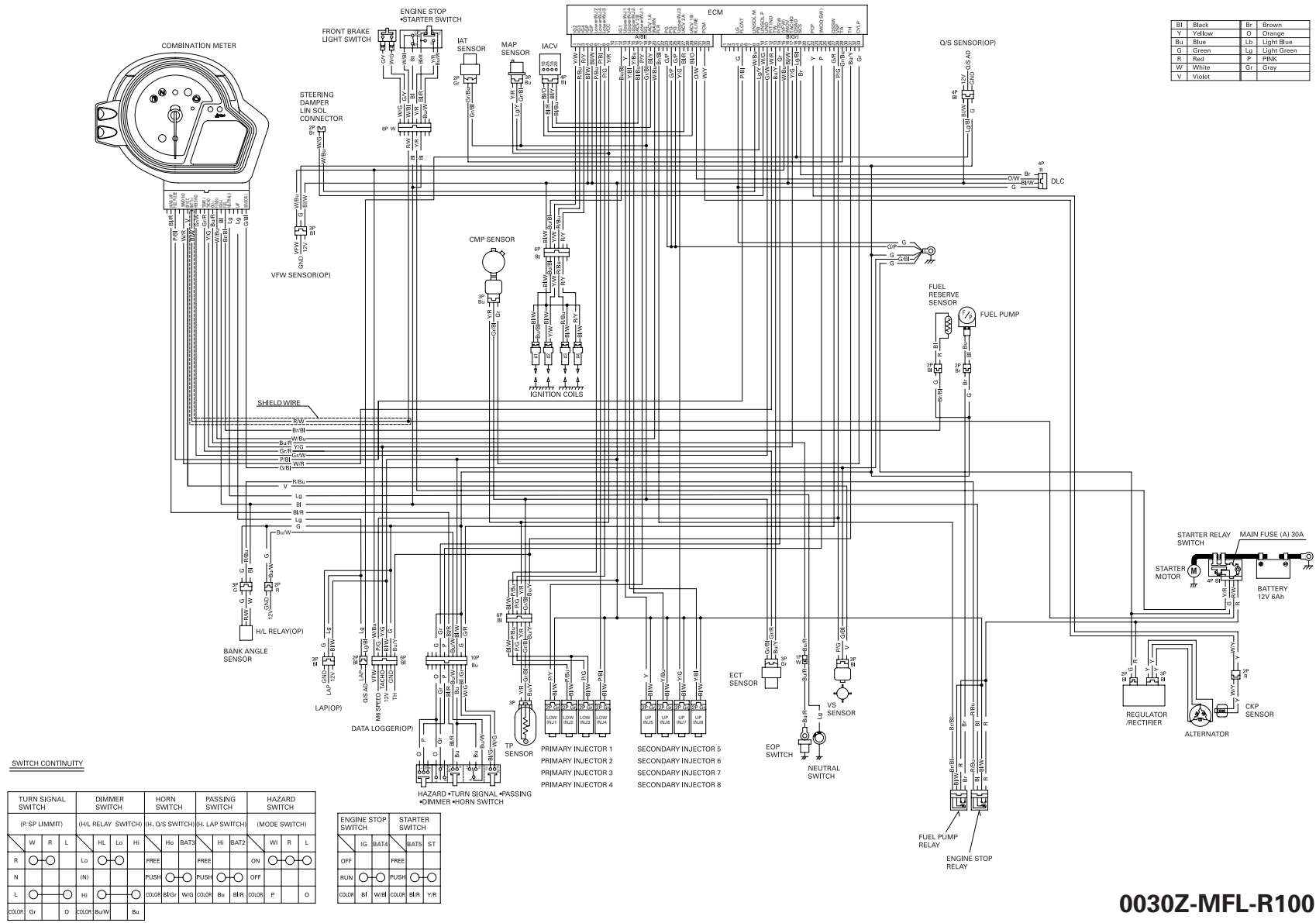

Bl	Black	Br	Brown
Y	Yellow	O	Orange
Bu	Blue	Lb	Light Blue
G	Green	Lg	Light Green
R	Red	P	PINK
W	White	Gr	Gray
V	Violet		

SWITCH CONTINUITY

TURN SIGNAL SWITCH (R SP LIMIT)			DIMMER SWITCH (HL RELAY SWITCH)			HORN SWITCH (H O/S SWITCH)			PASSING SWITCH (H LAP SWITCH)			HAZARD SWITCH (MODE SWITCH)		
W	R	L	HL	Lo	Hi	Ho	BAT3	Hi	BAT2	Wl	R	L		
R	○	○	Lo	○	○	FREE	FREE	○	○	ON	○	○		
N			(N)			PUSH	○	PUSH	○	OFF				
L	○	○	Hi	○	○	COLOR	BlGr	Wg	COLOR	Bu	BRR	COLOR	P	
COLOR	Gr	O	COLOR	BuW	Bu								O	

ENGINE STOP SWITCH			STARTER SWITCH		
IG	BAT4	BATS	ST		
OFF	FREE				
RUN	○	PUSH	○		
COLOR	Bl	WBl	COLOR	BRR	YR

0030Z-MFL-R100

Replacement Parts

Refer to the CBR1000RR SHOP MANUAL (62MFL00) for replacement procedure.

Spark plugs:

Replace the spark plugs with the racing kit plugs.

- 31910-NLR-A31 PLUG, SPARK, R0459A-10

No.	Part Number	Item	Q'ty
	06110-NLR-A30	Engine Power-up Kit, SBK	
1	14110-MFL-R10	Camshaft comp., IN	1
2	14210-MFL-R10	Camshaft comp., EX	1
4	14321-NLR-A30	Sprocket, cam	2
7	14751-MFL-R10	Spring IN, valve outer (color: brown)	8
7	14752-MFL-R10	Spring IN, valve inner (color: brown)	8
8	14761-MFL-R10	Spring EX, valve (color: sky blue)	8
9	90082-NL9-710	Bolt, flange knock, 7 x 10.5	4
10	90488-425-000	Washer, sealing 6 mm	2

Modifying the Cylinder Head Ports

Reworking on valve ports

- On the CBR1000RR, reworking the valve ports will have little effect because the machine is intended for competition use.
- However, you may improve breathing and encourage easier transfer of spent gases by removing the height difference between the valve seat and ports, and burrs or roughnesses on port surfaces.

Intake port

- Grind the insulator bore as indicated in the illustration below, then grind the intake port so there is no height difference between the insulator and intake port.
- Grind the intake port as indicated in the illustration below.
- Lightly polish the other surfaces using an emery cloth.

Exhaust port

- Grind the exhaust port as indicated in the illustration below.
- Lightly polish the other surfaces using an emery cloth.

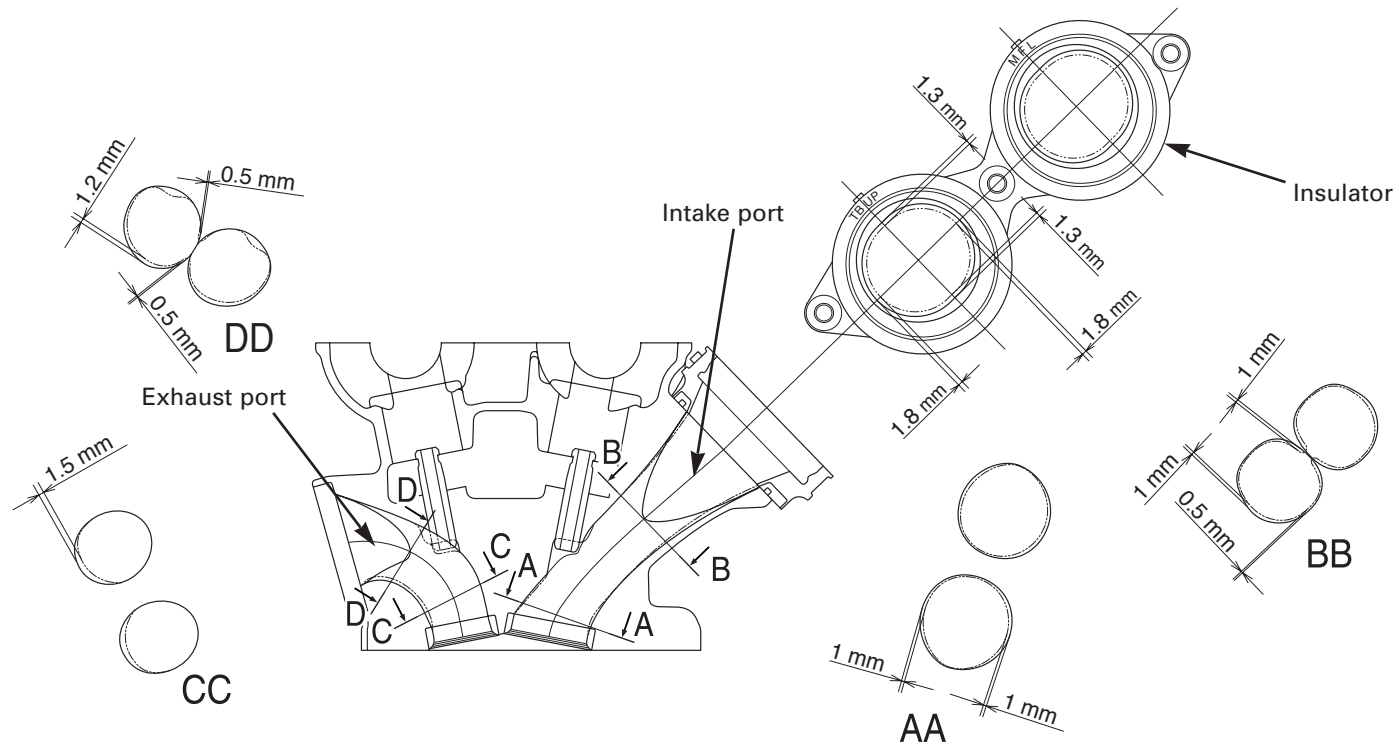

Adjusting the Compression Ratio

Grind the cylinder head mating surface using the following procedure.

Grind the cylinder head mating surface within 0.25 mm (0.010 in) by machining roughness 8S. Finish the surface using an oil stone.

Expected compression ratio: 13.1 : 1

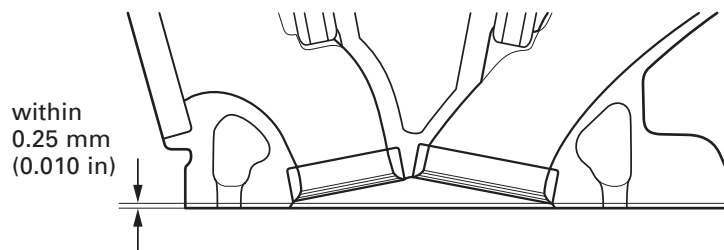

Select the cylinder head gasket as follows:

1. Prepare number of the cylinder head dummy collars for the cylinder head gasket selection as shown below.

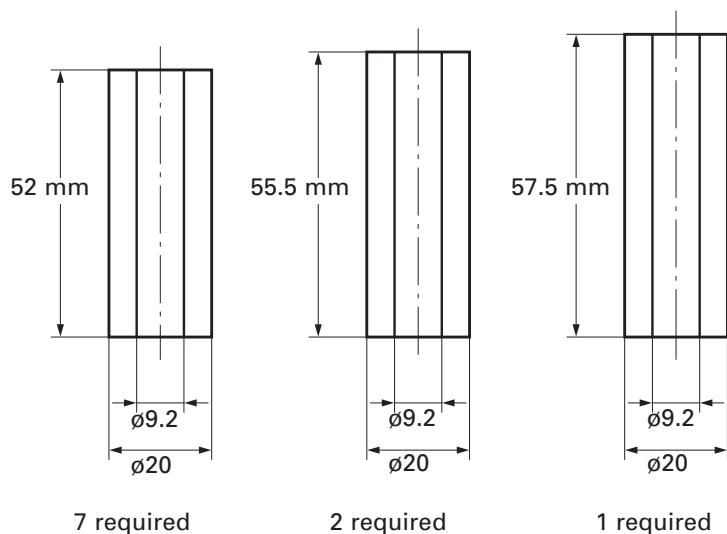

2. Temporarily install the cylinder gasket and cylinder.

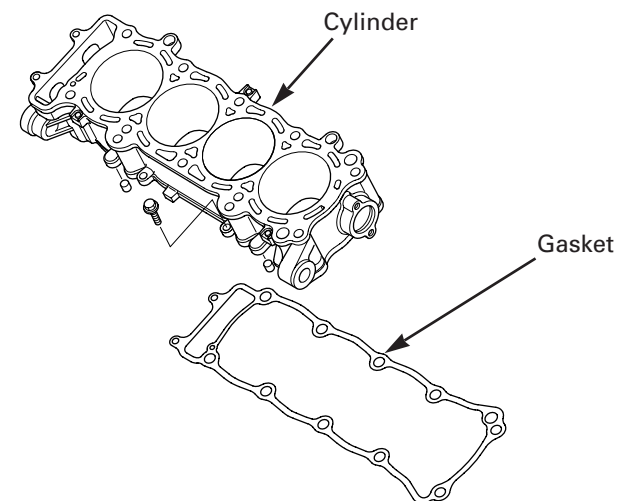

3. Remove the carbon deposits from the piston heads, and then install the pistons into the cylinder.

4. Install the cylinder head dummy collars into proper locations. When installing the collars, install the cutted used gasket between the cylinder and dummy collars.

Install the cylinder head mounting nuts, then tighten them to the specified torque (see page 2-13 for tightening procedure).

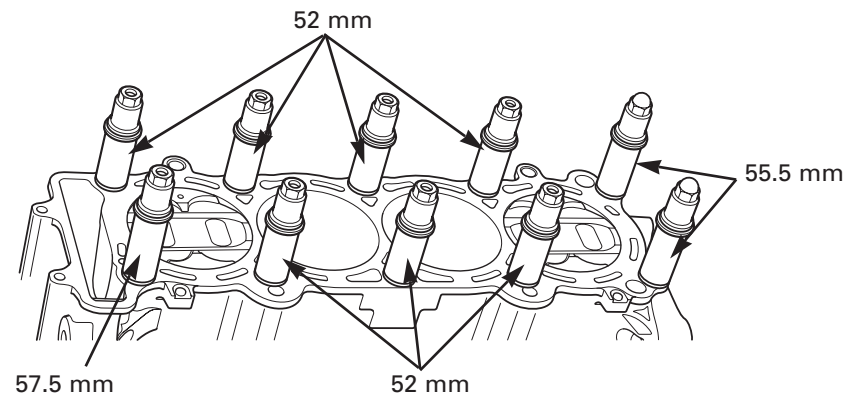

Racing Kit

4. Measure the clearance between the upper surface of the cylinder and the piston head at the 2 points on intake and exhaust.

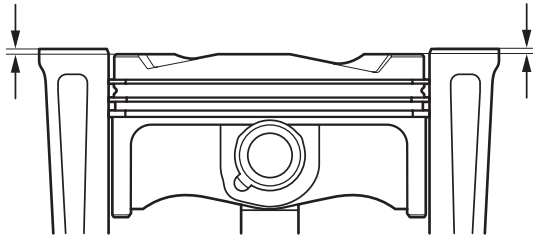

5. Calculate the average value.
Measure the clearance on each cylinder, select the cylinder head gasket from the minimum value.

Clearance	Gasket (t= thickness)	Identification color
0 – 0.05 mm	0.75 t	Yellow
0.05 – 0.10 mm	0.70 t	Green
0.10 – 0.15 mm	0.65 t	Orange
0.15 – 0.20 mm	0.60 t	—
0.20 – 0.25 mm	0.55 t	Blue

If the clearance is out of range, replace the cylinder gasket and follow the procedure 1 to 4.

Cylinder head gasket:

Part number	Gasket (t= thickness)	Identification color
12251-NLR-A31	0.55 t	Blue
12251-MFL-003	0.60 t (standard)	—
12252-NLR-A31	0.65 t	Orange
12253-NLR-A31	0.70 t	Green
12254-NLR-A31	0.75 t	Yellow

Cylinder gasket:

Part number	Gasket (t= thickness)	Identification mark
12193-NLR-A31	0.15 t	15
12191-NLR-A31	0.20 t	20
12191-MFL-003	0.25 t (standard)	—
12192-NLR-A31	0.30 t	30

Inlet Valve Seat Maintenance

When replacing the inlet valve, maintain the valve seat.

Valve seat width: 0.8 mm (0.03 in)

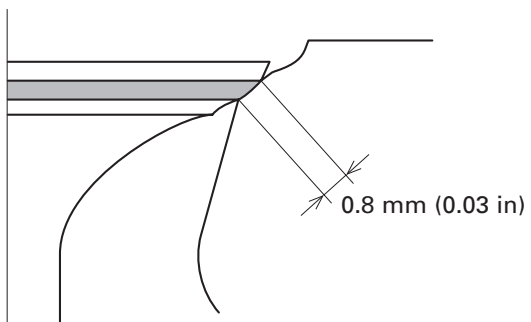

Note:

- When the exhaust valve seat maintenance is needed, make sure the exhaust valve seat width are 1.0 mm (0.04 in) as well as the standard.
- When assembling the valve, be careful not to damage the valve using the cotter. If the valve is damaged, replace it with a new one.

Racing Kit

Modifying Crankcase

Prepare the following reference seats for modifying the crankcase.

Seat A

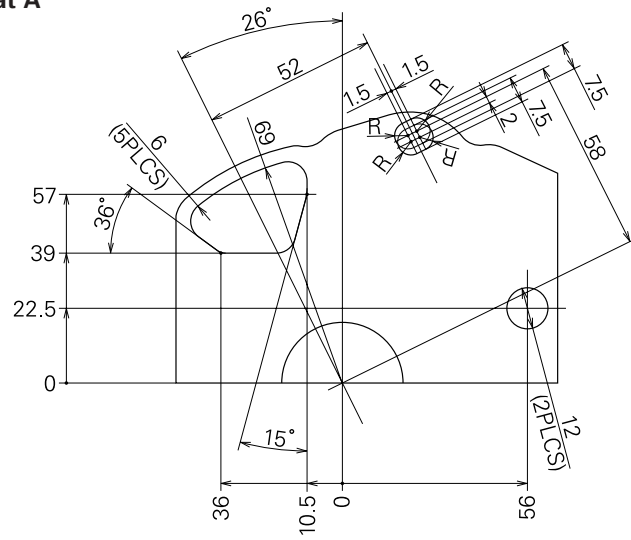

Seat B

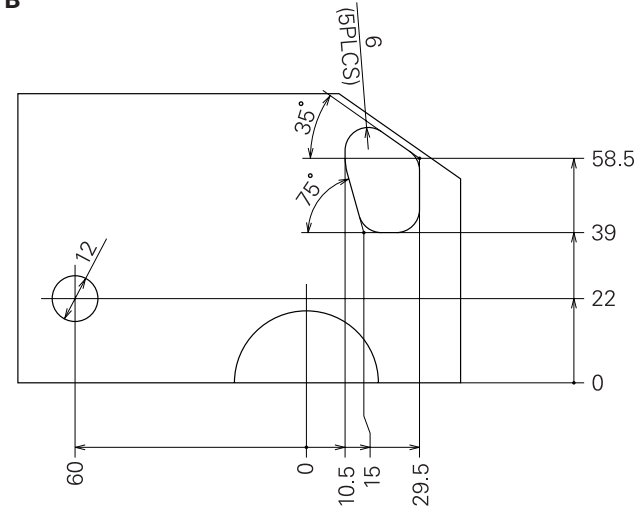

Seat C

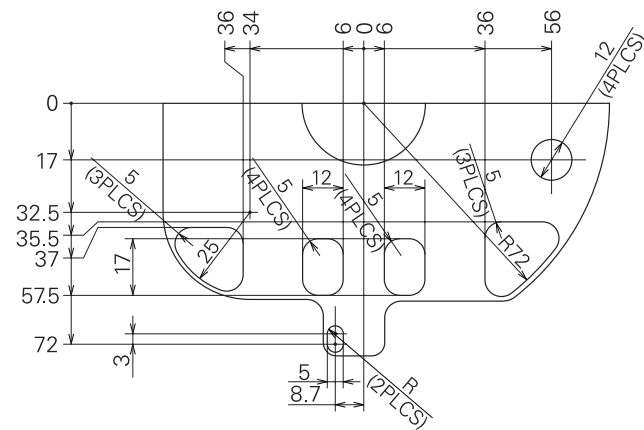

Upper Crankcase

Make holes in the left side of the upper crankcase using reference seat A.

Section AA:

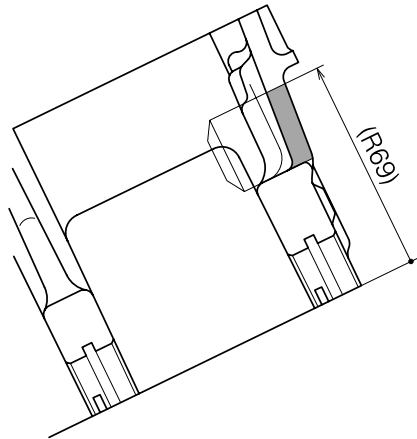

Section BB:

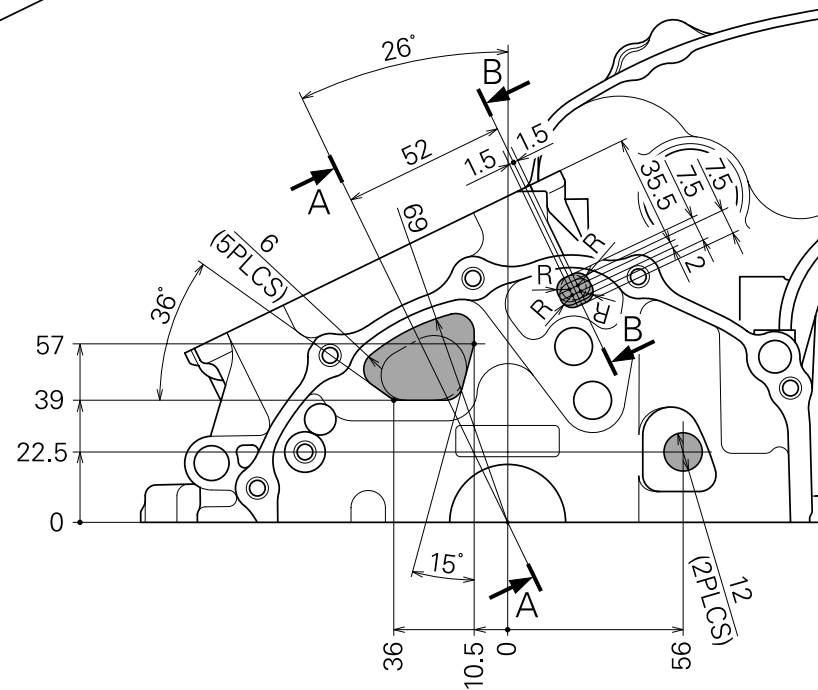
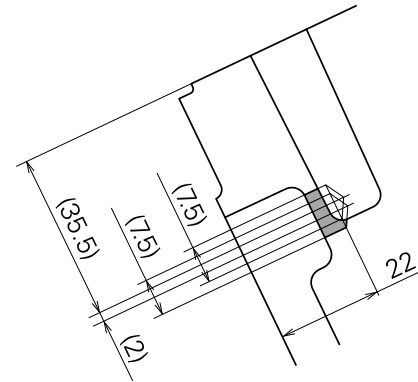

Racing Kit

Upper Crankcase

Make holes in the right side of the upper crankcase using reference seat B.

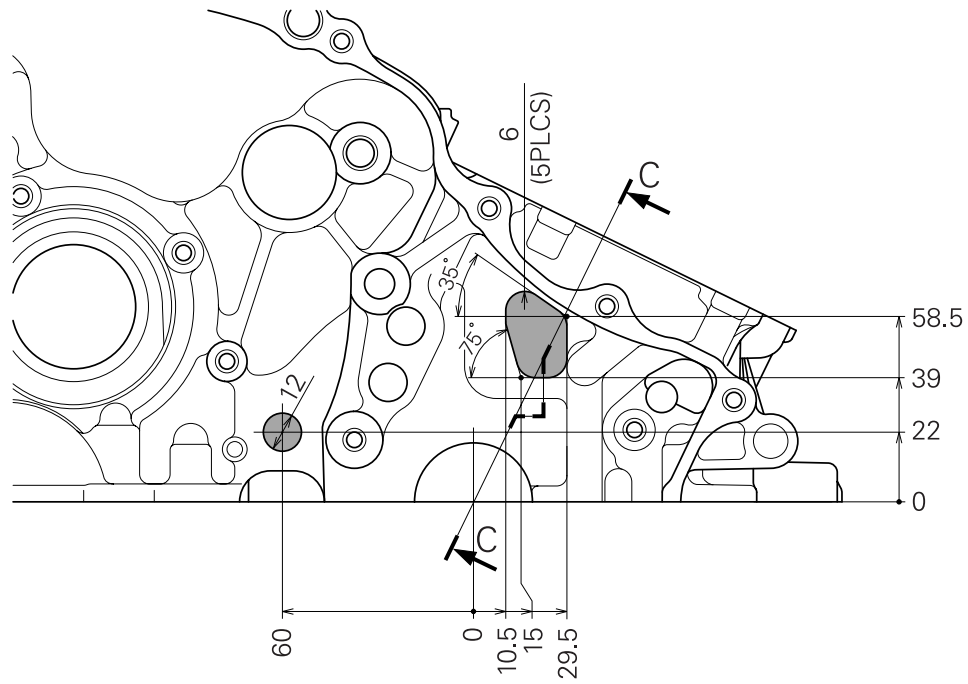

Section CC:

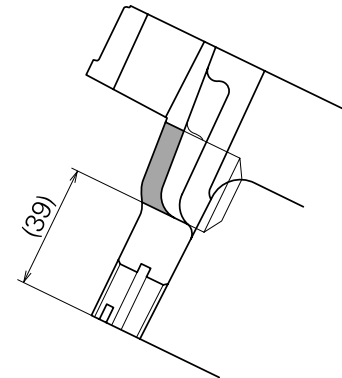

Lower Crankcase

Make four 12 mm holes in the lower crankcase using reference seat C.
 Make holes in the lower crankcase using reference seat C.
 If the grind machine cannot be used, grind with a hand grinding tool.

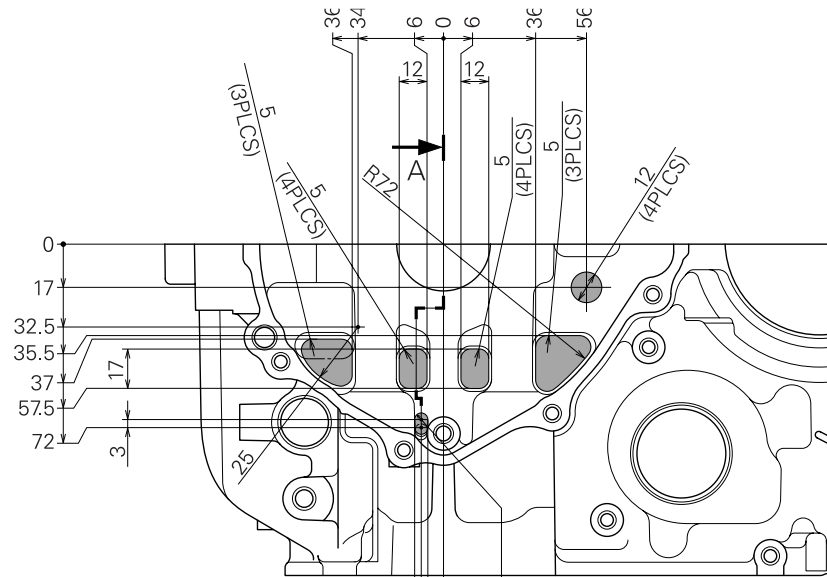

Section AA:

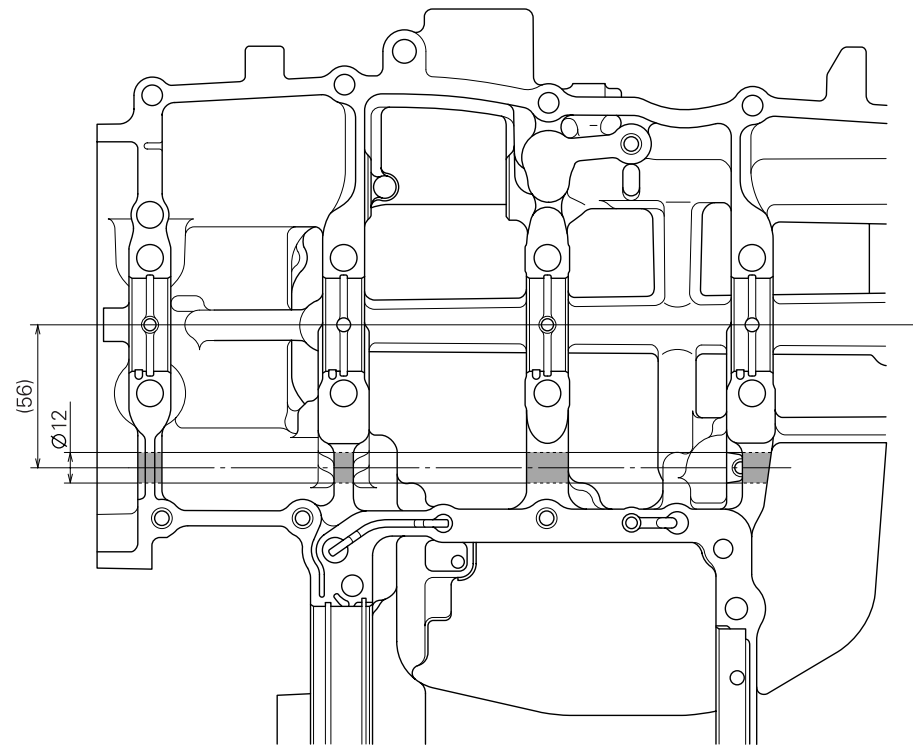
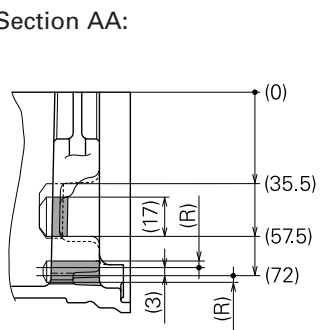

Racing Kit

Oil Pressure Relief Valve Replacement

1. Remove and disassemble the oil pump.
2. Clean the oil pump thoroughly.
3. Replace the oil pump pressure relief valve with the racing kit.
4. Apply oil to the oil pump rotors, then assemble the oil pump in the reverse order of disassembly.

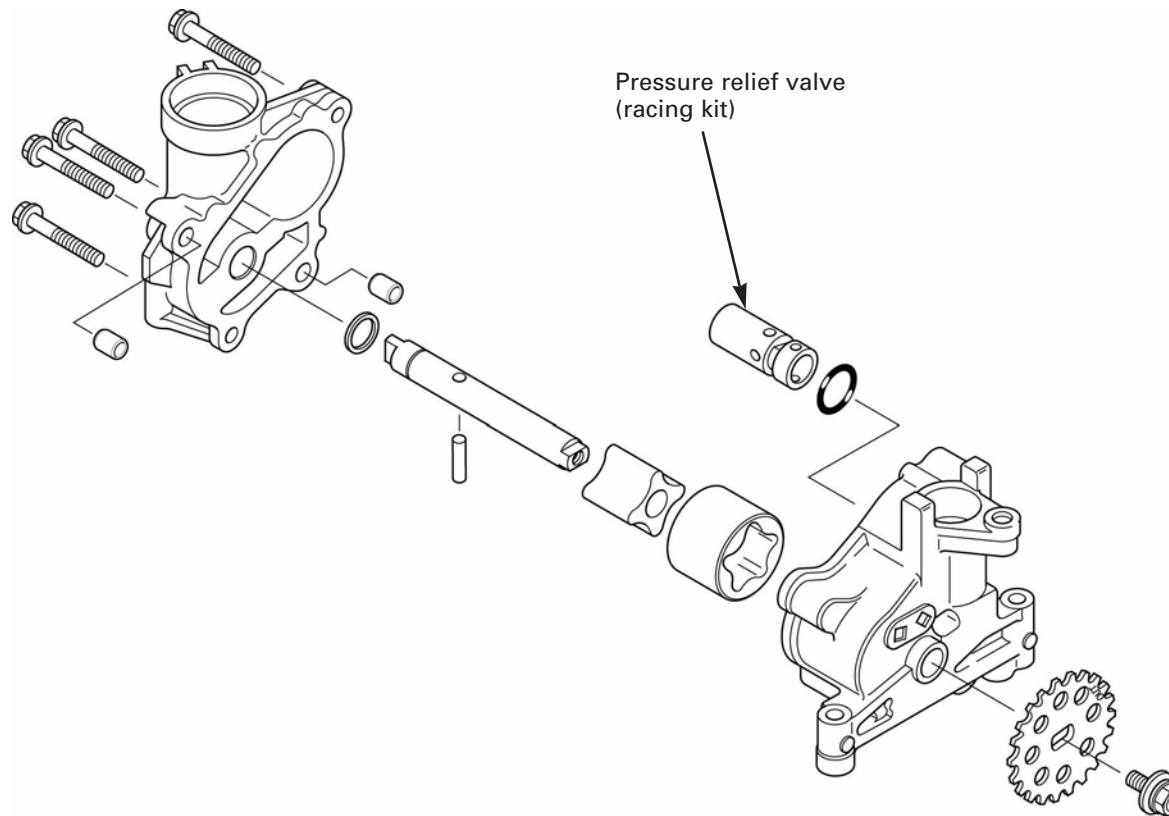

Cam Sprocket Kit Installation

Racing kit sprockets have two kind of bolt holes.

Long bolt holes are used when you adjust the valve timing.

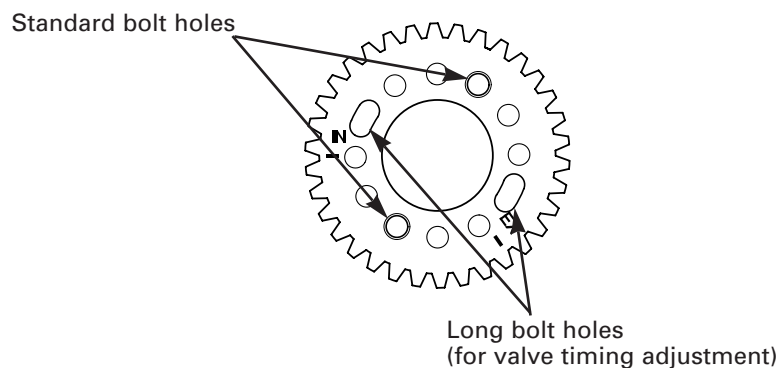

If you are not able to be measure the valve timing:

Use the standard bolt holes on the racing kit cam sprockets.
Place the No.1/4 pistons at TDC (Top Dead Center).
Install the cam sprocket with the No.4 camshaft cam lobes facing up as shown.

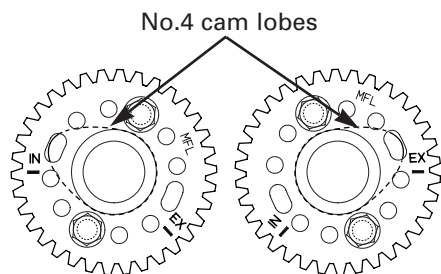

Valve timing (when using the standard bolt holes)

Intake	Opens	21° BTDC
	Close	54° ABDC
Exhaust	Opens	54° BBDC
	Close	16° ATDC

Apply Honda Ultra E-1 oil to the racing kit cam sprocket bolt threads and seating surface, then install and tighten them to the specified torque.

Torque: 22 N•m (2.2 kgf•m, 14 lbf•ft)

Turn the crankshaft clockwise turn, align the "T" mark on the starter clutch outer with the index mark on the right crankcase cover (the No.1/4 piston at TDC).

Install the camshafts onto the cylinder head.
Make sure that the timing marks on the cam sprockets are facing outward and flush with the cylinder head upper surface as shown.

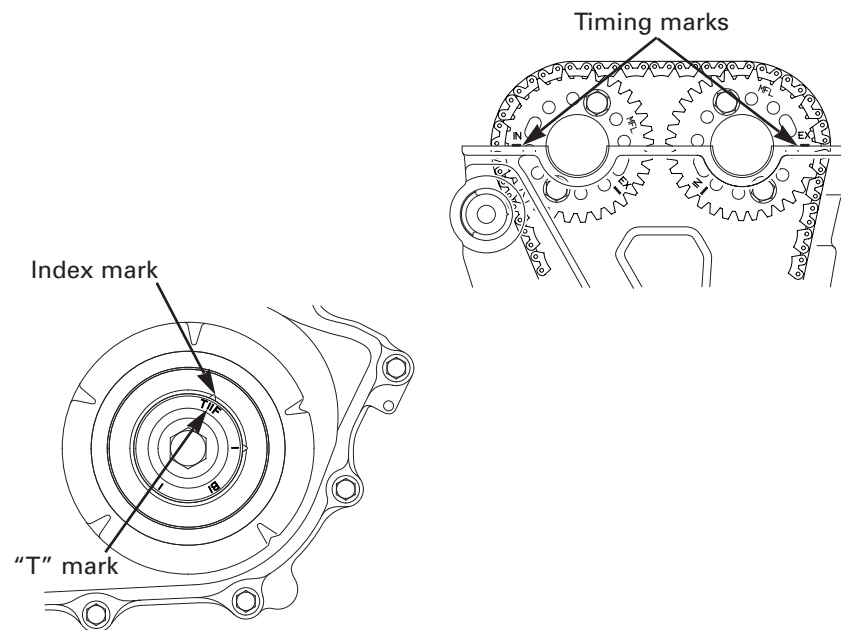

Racing Kit

If you are able to measure the valve timing:

Install the racing kit cam sprockets to the camshafts using the long bolt holes. Install the cam sprockets with the No.3 cam lobes facing up and outward as shown.

Apply Honda Ultra E-1 oil to the racing kit cam sprocket bolt threads and seating surface, temporarily tighten them.

- When tightening the sprocket bolts temporarily, push the intake cam sprocket to retard direction fully, and the exhaust cam sprocket to advance direction fully as shown.

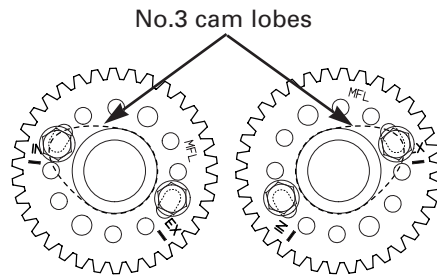

Place the No.2/3 pistons at TDC (Top Dead Center) and the starter clutch outer index line (180° from the "T" mark) aligns with the index mark on the right crankcase cover as shown.

Install the camshafts onto the cylinder head.

Make sure that the timing marks on the cam sprockets are facing outward and are flush with the cylinder head upper surface as shown.

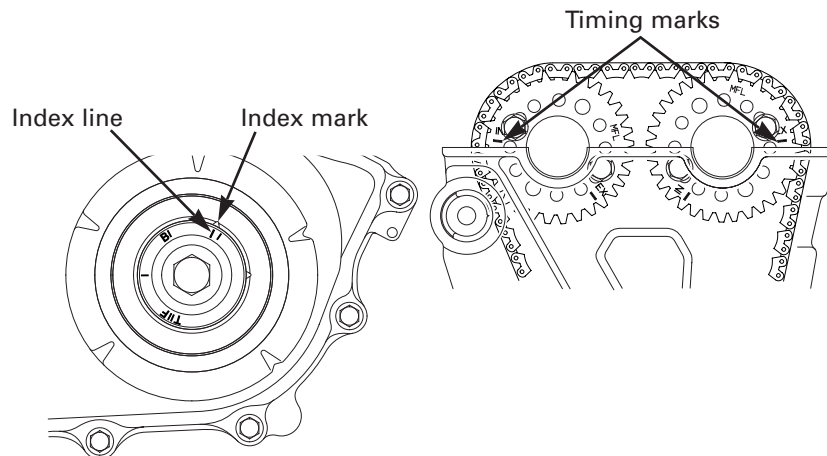

Measure the valve timing.

Recommended valve timing:

Intake	Opens	21° BTDC
	Close	54° ABDC
Exhaust	Opens	54° BBDC
	Close	16° ATDC

NOTICE

Do not set the overlap beyond the recommended values because the valves might touch to the piston head. Be careful not to touch the valve to the piston head when adjusting the valve timing.

Tighten the cam sprocket bolts to the specified torque.

Torque: 22 N·m (2.2 kgf·m, 14 lbf·ft)

NOTICE

Measure the piston and valve clearance and make sure the clearance is over the minimum values.

Piston and valve clearance (minimum):

IN: 1.5 mm
EX: 1.6 mm

If the measured values are below the minimum values, adjust the valve timing so that the clearance is over the minimum values.

Example:

If the intake valve and piston clearance is 1.1 mm, adjust the valve timing as noted below, and recheck the valve and piston clearance.

Intake	Opens	21° BTDC to 20° BTDC
	Close	54° ABDC to 55° ABDC
Exhaust	Opens	54° BTDC to 55° BTDC
	Close	16° ABDC to 15° ABDC

Cylinder Head Bolt Tightening

If the cylinder head, tightening nut, washer and/or stud bolt are replaced, tighten the cylinder head nuts as follows;

Break-in procedure:

1. Clean the stud bolts, nuts, washers and seating surfaces of the cylinder head.
2. Apply Honda Ultra E-1 oil to the stud bolts, nut, washer and seating surface of the cylinder head.
3. Install the washers and nuts, tighten the cylinder head nuts to the specified torque in numerical order as noted in the illustration.
4. Retighten the cylinder head nuts to the specified torque in numerical order as noted in the illustration.

Torque: 25 N·m (2.5 kgf·m, 18 lbf·ft)

5. Further tighten the cylinder head nuts 67.5 degrees in numerical order.
6. Further tighten the cylinder head nuts 67.5 degrees in numerical order again (total; 135 degrees).
7. Loosen and remove the cylinder head nuts and washers.

Final tightening procedure:

1. Clean the stud bolts, nuts, washers and seating surfaces of the cylinder head.
2. Apply Honda Ultra E-1 oil to the stud bolts, nuts, washers and seating surfaces of the cylinder head.
3. Tighten the cylinder head nuts to the specified torque in numerical order as noted in the illustration.
4. Retighten the cylinder head nuts to the specified torque in numerical order as noted in the illustration.

Torque: 25 N·m (2.5 kgf·m, 18 lbf·ft)

5. Further tighten the cylinder head nuts 67.5 degrees in numerical order.
6. Further tighten the cylinder head nuts 67.5 degrees in numerical order again (total; 135 degrees).

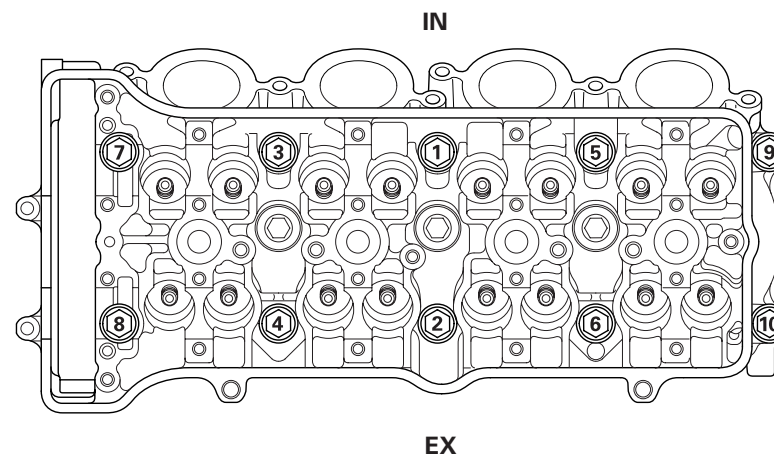

Racing Kit

ACG Set Installation

1. Remove the standard AC generator cover and flywheel.
2. Clean any oil off from the crankshaft taper and flywheel taper.
3. Install and racing kit flywheel to the crankshaft.
4. Apply engine oil to the flywheel mounting bolt threads and seating surface.
5. Install the bolt with washer, tighten the bolt to the specified torque.

Torque: 135 N•m (13.8 kgf•m, 100 lbf•ft)

Loosen the bolt and retighten the bolt to the specified torque again. Follow above procedure once more (temporarily tighten the bolt three times).

Tighten the bolt to the following torque, then further tighten the bolt 60°.

Torque: 15 N•m (1.5 kgf•m, 11 lbf•ft) + 60°

After tighten the bolt, make sure the tightening torque is more than 128 N•m (13.0 kgf•m, 94 lbf•ft).

6. Apply locking agent to the stator mounting bolt threads. Install the racing kit stator onto the racing kit AC generator cover, then tighten the stator mounting bolts and the wire clamp bolt to the specified torque.

Torque: 12 N•m (1.2 kgf•m, 9 lbf•ft)

7. Install the new gasket and AC generator cover onto the crankcase, tighten the bolts securely.

- We recommend that the racing kit flywheel bolt (90003-NL9-000) be used whenever the standard flywheel is installed.
- When using the racing kit flywheel bolt, follow the racing kit tightening method and torque value.
- Replace the flywheel bolt with a new one every 6,000 km (3,700 mi).
- When using the standard flywheel and bolt;
 - flywheel reinstallation, temporarily tighten the bolt 1 time.
 - flywheel and/or crankshaft are replaced, temporarily tighten the bolt two times.
- Do not interchange the standard bolt and the racing kit bolt (see illustration).

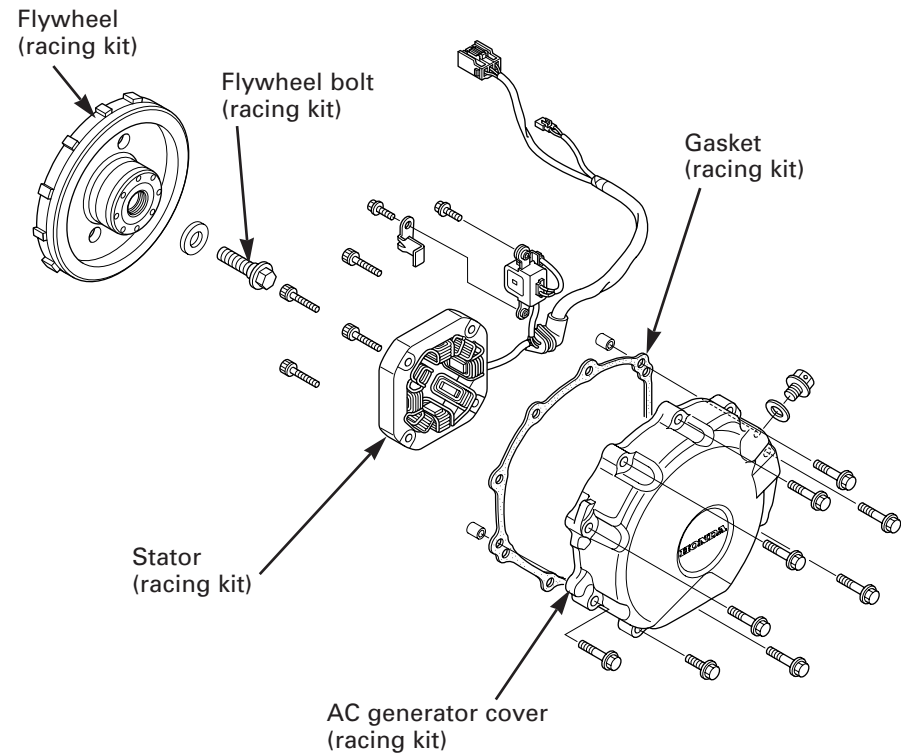

Flywheel bolt

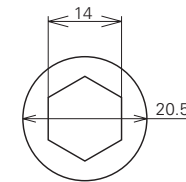

Standard bolt
(90003-MN4-000)

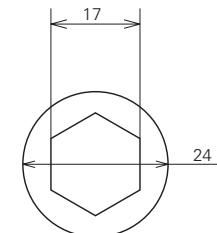

Racing kit bolt
(90003-NL9-000)

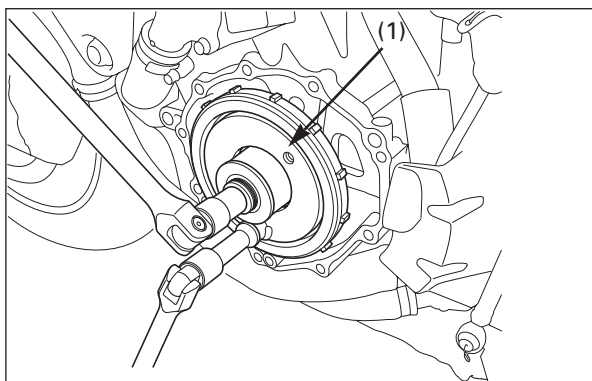

(1) ROTOR HOLDER

Flywheel Holding

Hold the flywheel with a rotor holder by inserting the holder bosses into the flywheel holes and seat the holder into the flywheel.

Loosen and remove the flywheel bolt.

Tool:

Rotor holder **89030-NL9-711**

Remove the flywheel from the crankshaft using the special tools for standard vehicle.

Tools:

Flywheel holder **07725-0040001**

Outside screw puller **07933-4250000**

(use only M18 x 1.5 puller)

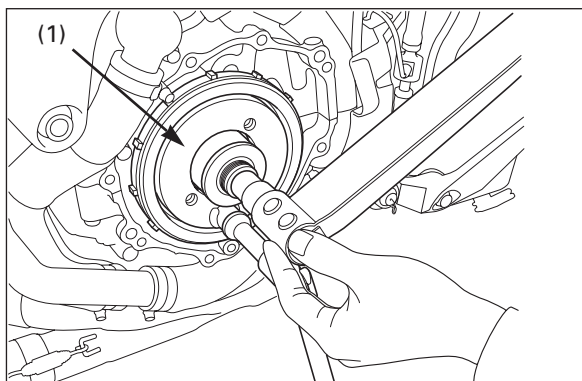

(1) ROTOR HOLDER

Install the flywheel onto the crankshaft.
Apply oil to the flywheel bolt threads and seating surface.

Install the washer and flywheel bolt.

Hold the flywheel with a rotor holder by inserting the holder bosses into the flywheel holes and seat the holder into the flywheel.

Make sure the rotor holder tool seats flywheel properly.

Tool:

Rotor holder **89030-NL9-711**

Refer to page 2-14 for detail of the tightening procedure.

Racing Kit

Transmission Set Installation

1. Remove and disassemble the transmission (see shop manual)
2. Assemble the transmission using the racing kit mainshaft and gears.

NOTICE

- Do not assemble the standard gear with the racing kit gear.
- When disassembling, always replace the circlips with new ones.
- Always install the thrust washer and snap ring with the chamfered (rolled) edge facing away from the thrust load as shown.

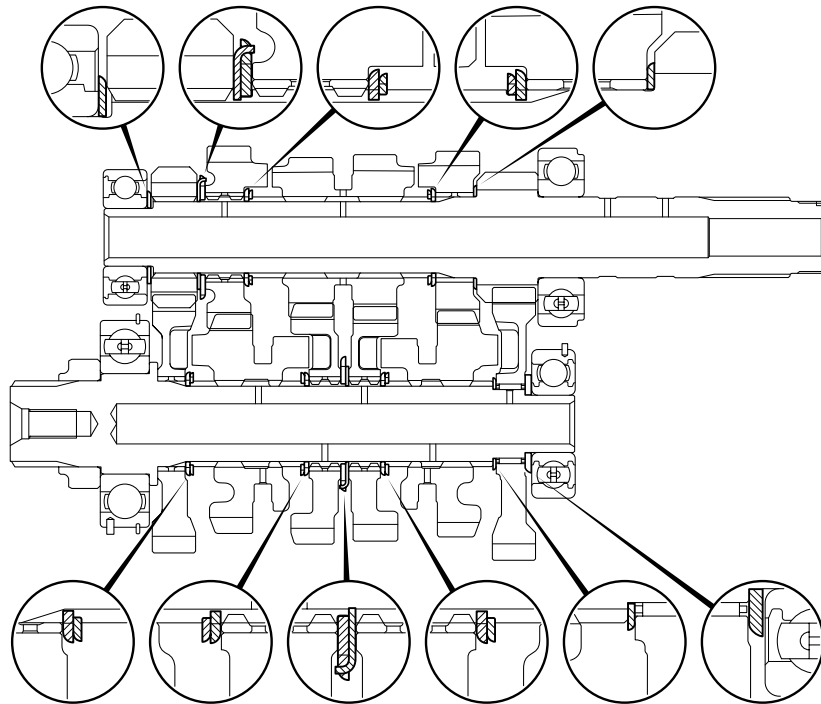

	Standard Gear ratio (T= Teeth)	Racing kit			
		Gear ratio (T= Teeth)			
		P1 (R/B)	P2	P3	P4
1st	2.286 (14/32T)	2.286 (14/32T)	2.400 (15/36T)	2.214 (14/31T)	—
2nd	1.778 (18/32T)	1.941 (17/33T)	2.000 (18/36T)	1.882 (17/32T)	—
3rd	1.045 (22/23T)	1.667 (18/30T)	1.700 (20/34T)	1.632 (19/31T)	—
4th	1.333 (24/32T)	1.500 (20/30T)	1.526 (19/29T)	1.450 (20/29T)	—
5th	1.214 (28/34T)	1.348 (23/31T)	1.400 (20/28T)	1.368 (19/26T)	1.318 (22/29T)
6th	1.138 (29/33T)	1.227 (22/27T)	1.273 (22/28T)	1.250 (24/30T)	1.200 (25/30T)

Replace the vehicle speed sensor with the racing kit. Racing kit speed sensor is identified with the paint (red color) as shown.

Identification paint (red)

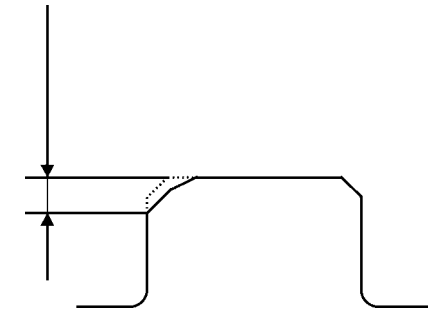

Check the gear dog edges for wear.

Service limit: 1.0 mm (0.04 in)

Gear jumps may occur if the gear dog edges are worn. Replace gears worn to the service limit with new gears.

Optional Transmission Gears

The following optional transmission gears are available for use in the transmission. Care should be taken substituting optional gears for the standard gears.

Gear	Mainshaft			Countershaft							
	Plan	Ratio	Teeth	Plan	Teeth	Part Number	Identify	Plan	Teeth	Part Number	Identify
1st	P-2	2.400	15T	P-2	15T	23212-NLR-A30	P-2	P-2	36T	23422-NLR-A30	P-2
	P-1	2.286	14T	P-1	14T	23211-MFL-R10	2 grooves	P-1	32T	23421-MFL-R10	2 grooves
	P-3	2.214	14T	P-3	14T	23213-NLR-A30	P-3	P-3	31T	23423-NLR-A30	P-3
2nd	P-2	2.000	18T	P-2	18T	23432-NLR-A30	P-2	P-2	36T	23442-NLR-A30	P-2
	P-1	1.941	17T	P-1	17T	23431-MFL-R10	2 grooves	P-1	33T	23441-MFL-R10	2 grooves
	P-3	1.882	17T	P-3	17T	23433-NLR-A30	P-3	P-3	32T	23443-NLR-A30	P-3
3rd	P-2	1.700	20T	Refer to M3/4 gear matrix chart below				P-2	34T	23462-NLR-A30	C3, P-2
	P-1	1.667	18T					P-1	30T	23461-MFL-R10	2 grooves
	P-3	1.632	19T					P-3	31T	23463-NLR-A30	C3, P-3
4th	P-2	1.526	19T					P-2	29T	23482-NLR-A30	C4, P-2
	P-1	1.500	20T					P-1	30T	23481-MFL-R10	2 grooves
	P-3	1.450	20T					P-3	29T	23483-NLR-A30	C4, P-3
5th	P-2	1.400	20T	23492-NLR-A30	M5, P-2	P-2	28T	23502-NLR-A30	C5, P-2		
	P-3	1.368	19T	23493-NLR-A30	M5, P-3	P-3	26T	23503-NLR-A30	C5, P-3		
	P-1	1.348	23T	23491-MFL-R10	2 grooves	P-1	31T	23501-MFL-R10	2 grooves		
	P-4	1.318	22T	23494-NLR-A30	M5, P-4	P-4	29T	23504-NLR-A30	C5, P-4		
6th	P-2	1.273	22T	23512-NLR-A30	M6, P-2	P-2	28T	23522-NLR-A30	C6, P-2		
	P-3	1.250	24T	23513-NLR-A30	M6, P-3	P-3	30T	23523-NLR-A30	C6, P-3		
	P-1	1.227	22T	23511-MFL-R10	2 grooves	P-1	27T	23521-MFL-R10	2 grooves		
	P-4	1.200	25T	23514-NLR-A30	M6, P-4	P-4	30T	23524-NLR-A30	C6, P-4		

M3/4 Gear matrix

M3-4 Plan		M3 Plan		
		P-1	P-2	P-3
M4 Plan	P-1	P-11	P-21	P-31
	P-2	P-12	P-22	P-32

M3-4 Plan		3rd Plan		
		P-1	P-2	P-3
4th Plan	P-1	P-11	P-21	P-31
	P-2	P-12	P-22	P-32
	P-3	P-11	P-21	P-31

M3-4			
Plan	Part Number	Identify	Combi
P-11	23451-MFL-R10	2 grooves	P-1/P-1
P-12	23452-NLR-A30	P-12	P-1/P-2
P-21	23453-NLR-A30	P-21	P-2/P-1
P-22	23454-NLR-A30	P-22	P-2/P-2
P-31	23455-NLR-A30	P-31	P-3/P-1
P-32	23456-NLR-A30	P-32	P-3/P-2

Racing Kit

Speed list (14,000 rpm) Primary reduction: 46/79, Tire radius: 0.323 m, Tire circumference: 2.03 m

Gear		No. of teeth		Gear ratio	17	17	17	16	17	16	17	16	17	16	17	16	17	16	16	16	16	Drive
		M	C		38	39	40	38	41	39	42	40	43	41	44	42	45	43	46	44	45	46
1st	P-2	15	36	2.400	185	180	175	174	171	169	167	165	163	161	159	157	156	153	152	150	147	143
	P-1	14	32	2.286	194	189	184	182	180	178	175	173	171	169	167	165	164	161	160	157	154	151
	P-3	14	31	2.214	200	195	190	188	185	183	181	179	177	174	173	170	169	166	165	163	159	155
2nd	P-2	18	36	2.000	222	216	210	208	205	203	200	198	196	193	191	189	187	184	183	180	176	172
	P-1	17	33	1.941	228	222	217	215	212	209	206	204	202	199	197	194	193	190	188	185	181	177
	P-3	17	32	1.882	235	229	224	222	218	216	213	210	208	205	203	200	199	196	194	191	187	183
3rd	P-2	20	34	1.700	261	254	248	245	242	239	236	233	230	227	225	222	220	217	215	212	207	203
	P-1	18	30	1.667	266	259	253	250	246	244	241	238	235	232	230	226	224	221	220	216	211	207
	P-3	19	31	1.632	272	265	258	256	252	249	246	243	240	237	235	231	229	226	224	221	216	211
4th	P-2	19	29	1.526	290	283	276	273	269	266	263	260	257	253	251	247	245	241	240	236	231	226
	P-1	20	30	1.500	296	288	281	278	274	271	267	264	261	258	255	252	249	246	244	240	235	230
	P-3	20	29	1.450	306	298	290	288	283	280	277	273	270	267	264	260	258	254	252	248	243	238
5th	P-2	20	28	1.400	317	309	301	298	293	290	286	283	280	276	273	270	267	263	262	257	252	246
	P-3	19	26	1.368	324	316	308	305	300	297	293	290	286	283	280	276	274	269	268	263	257	252
	P-1	23	31	1.348	329	321	313	310	305	302	298	294	291	287	284	280	278	274	272	267	261	256
	P-4	22	29	1.318	336	328	320	317	312	308	304	301	297	293	290	286	284	280	278	273	267	261
6th	P-2	22	28	1.273	348	339	331	328	323	319	315	311	308	304	301	297	294	290	288	283	277	271
	P-3	24	30	1.250	355	346	337	334	329	325	321	317	313	309	306	302	299	295	293	288	282	276
	P-1	22	27	1.227	361	352	343	340	335	331	327	323	319	315	312	308	305	300	298	294	287	281
	P-4	25	30	1.200	370	360	351	348	342	339	334	330	327	322	319	315	312	307	305	300	294	287

Since the values in the speed list differ somewhat depending on the tire manufacturer and size, selection should be made based on the gear ratio.

Clutch Kit Installation

Remove the clutch discs and plates.

Install the racing kit judder spring and judder spring seat to the clutch center side.

Install the two racing kit clutch discs with their half cut-out side facing to the clutch center, and pink paint side facing to the pressure plate.

Replace the standard two clutch springs to the racing kit single spring.

Install the removed parts in the reverse order of removal.

Replace the clutch cable with the racing kit.

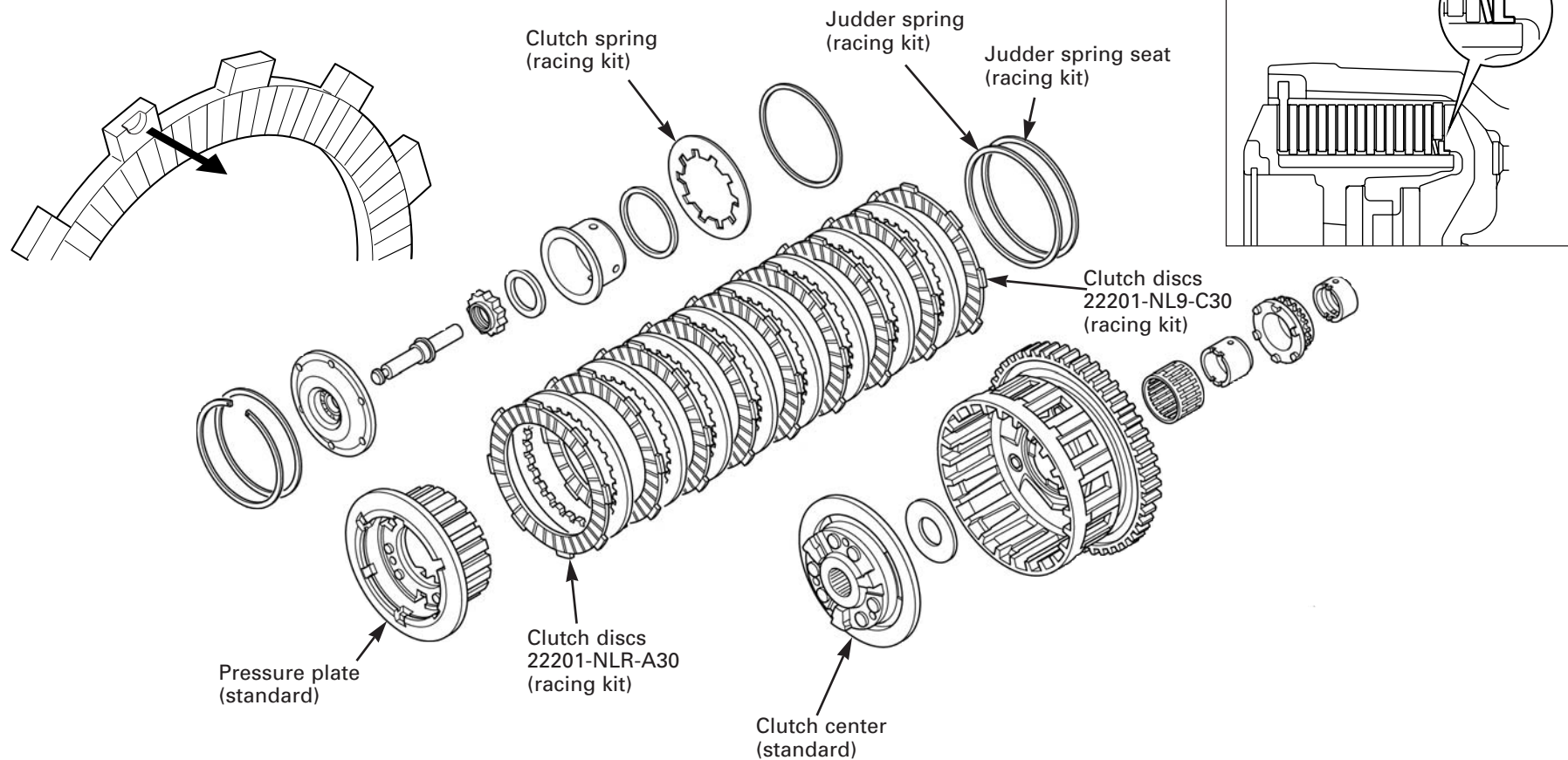

Note:

- Use total set height managed clutch disc set (part No: 06280-NLR-A30) when replacing the clutch discs/plates with new ones.
- Replace the judder spring, when replacing the clutch discs and plates.

Racing Kit

Main Journal Bolt Tightening

If the main journal bolts are replaced with new ones, tighten the main journal bolts as follows;

Break-in procedure:

1. Clean the bolts and threaded hole of the cylinder block.
2. Apply Honda Ultra E-1 oil to the main journal bolts threads and seating surface.
3. Tighten the main journal bolts to the specified torque in numerical order as noted in the illustration.

Torque: 20 N·m (2.0 kgf·m, 14 lbf·ft)

4. Further tighten the main journal bolts 60 degrees in numerical order.
5. Further tighten the main journal bolts 60 degrees in numerical order again (total; 120 degrees).
6. Loosen and remove the main journal bolts.

Final tightening procedure:

1. Clean the bolts and threaded hole of the cylinder block.
2. Apply Honda Ultra E-1 oil to the main journal bolts threads and seating surface.
3. Tighten the main journal bolts to the specified torque in numerical order as noted in the illustration.

Torque: 20 N·m (2.0 kgf·m, 14 lbf·ft)

4. Further tighten the main journal bolts 60 degrees in numerical order.
5. Further tighten the main journal bolts 60 degrees in numerical order (total; 120 degrees).

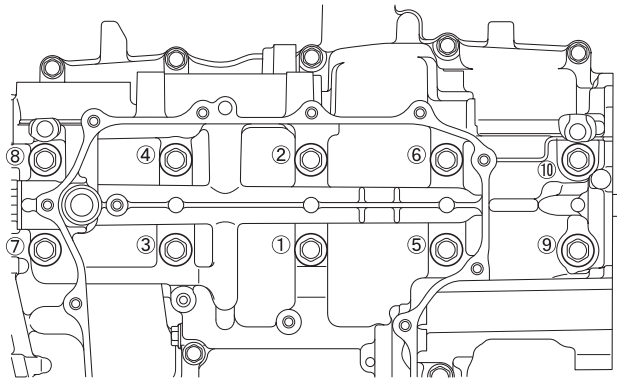

Connecting Rod Bolt Tightening

If the connecting rod bolts are replaced with new ones, tighten the connecting rod bolts as follows;

Break-in procedure:

1. Clean the connecting rod bolts, bolt holes and seating surfaces.
2. Apply Honda Ultra E-1 oil to the connecting rod bolts threads and seating surface.
3. First tighten the connecting rod bearing tab side bolt to the specified torque, then tighten the other bolt.

Torque: 27.5 N·m (2.8 kgf·m, 20 lbf·ft)

4. Further tighten the connecting rod bolts 45 degrees from bearing tab side bolt.
5. Further tighten the connecting rod bolts 45 degrees from bearing tab side bolt again (total; 90 degrees).
6. Loosen and remove the connecting rod bolts.

Final tightening procedure:

1. Clean the connecting rod bolts, bolt holes and seating surfaces.
2. Apply Honda Ultra E-1 oil to the connecting rod bolts threads and seating surface.
3. First tighten the connecting rod bearing tab side bolt to the specified torque, then tighten the other bolt.

Torque: 21.6 N·m (2.2 kgf·m, 16 lbf·ft)

4. Further tighten the connecting rod bolts 45 degrees from bearing tab side bolt.
5. Further tighten the connecting rod bolts 45 degrees from bearing tab side bolt again (total; 90 degrees).

Balancer Backlash Adjustment

Adjust the balancer backlash while the engine is off and cold (below 35°C/95°F).

Loosen the balancer shaft holder pinch bolt.

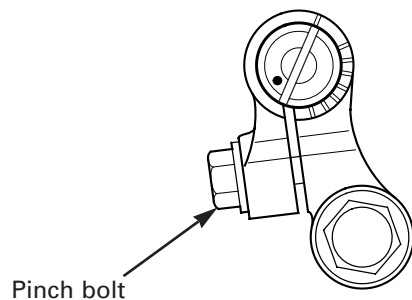

Remove the timing hole cap.
Turn the crankshaft clockwise, and align the "B" mark on the starter clutch outer with the index mark on the right crankcase cover.

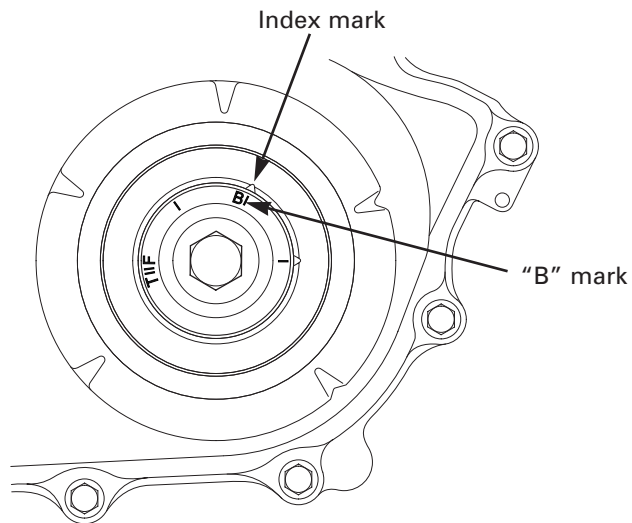

Turn the balancer shaft counterclockwise until the resistance is felt.
Mark the 4th index mark (center index) on the balancer shaft and balancer shaft holder.

Then turn the balancer shaft clockwise 2.5 graduations.

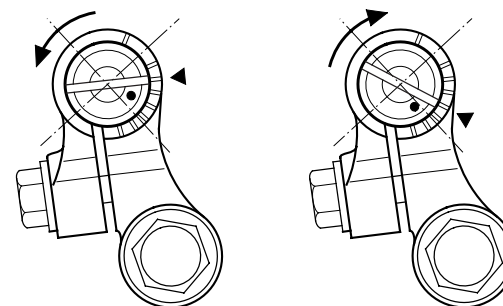

until the resistance is felt

Return 2.5 graduations

Tighten the balancer shaft holder pinch bolt to the specified torque.

Torque: 12 N·m (1.2 kgf·m, 9 lbf·ft)

Do not turn the balancer shaft more than necessary to avoid damage to the balancer gear, bearing and shaft.

Engine Hanger Tightening Sequence

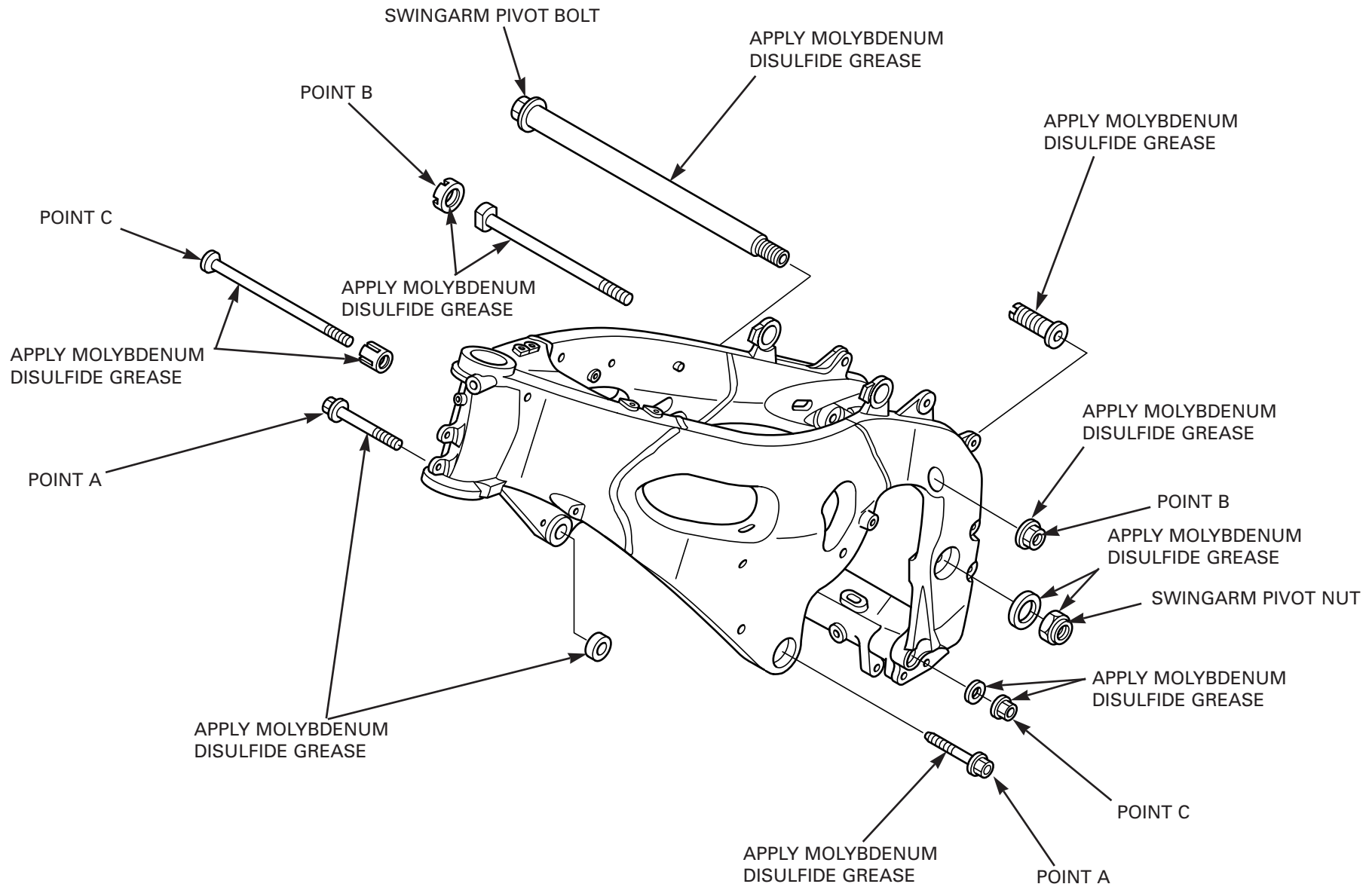

NOTICE

When using a lock nut wrench for an adjusting bolt lock nut, use a deflecting beam type torque wrench 20 inches long. The lock nut wrench increases the torque wrench's leverage, so the torque wrench reading will be less than the torque actually applied to the lock nut. The specification given is the actual torque applied to the lock nut, not the reading on the torque wrench. Do not overtighten the lock nut.

Apply molybdenum disulfide grease to the all mounting bolt threads and seating surface of the nuts.

Install and tighten the engine hanger bolts as follows:

1. Install the point B engine hanger adjusting collars fully from the inside of the frame. Install the point C engine hanger adjusting collars fully from the right of the frame.
2. Install the engine into the frame.
3. Install the rear upper engine hanger bolt (B), and align the bolt head with the adjusting collar groove.
4. Install the rear lower engine hanger bolt (C), and align the bolt head with the adjusting collar groove.
5. Install the point A engine hanger distance collar and bolts.
6. Install the swingarm pivot bolt, washer and nut.
7. Tighten the swingarm pivot nut to the specified torque.

Torque: 98 N•m (10.0 kgf•m, 72 lbf•ft)

8. Tighten the rear upper hanger adjusting bolt while turning the hanger bolt until it seats.
9. Tighten the rear upper engine hanger adjusting bolt (B) to the specified torque.

Torque: 9.8 N•m (1.0 kgf•m, 7 lbf•ft)

10. Tighten the rear upper engine hanger adjusting bolt lock nut (B) to the specified torque.

Tool:
Lock nut wrench, 5.8 x 46 mm
07VMA-MBB0100 or
07VMA-MBB0101

Torque:
Actual: 59 N•m (6.0 kgf•m, 43 lbf•ft)
Scale reading: 54 N•m (5.5 kgf•m, 40 lbf•ft)

11. Install the rear lower engine hanger nut (C), then tighten the nut to the specified torque while holding the hanger bolt.

Torque: 59 N•m (6.0 kgf•m, 43 lbf•ft)

12. Install the rear upper engine hanger nut (B), then tighten the nut to the specified torque while holding the hanger bolt.

Torque: 49 N•m (5.0 kgf•m, 36 lbf•ft)

13. Tighten the left side front engine hanger bolt (A) to the specified torque.

Torque: 59 N•m (6.0 kgf•m, 43 lbf•ft)

14. Tighten the right side front engine hanger bolt (A) to the specified torque.

Torque: 59 N•m (6.0 kgf•m, 43 lbf•ft)

Install the removed parts in the reverse order of removal.

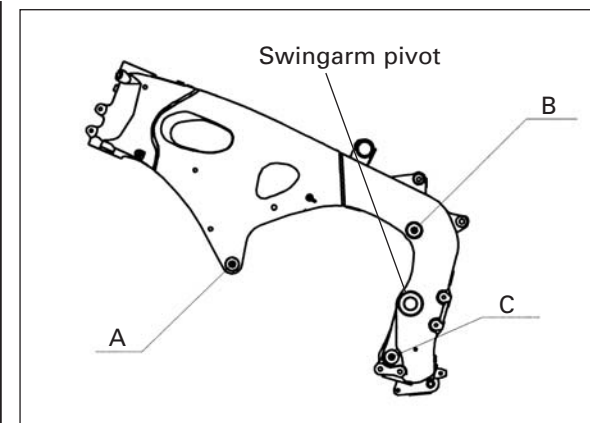

Racing Kit

Wire Lock

NOTICE

Before riding the machine, secure the following bolts and nuts:

- Engine oil filler cap
- Engine oil level dipstick/crankshaft hole cap
- Engine oil drain plug
- Oil filter cartridge/main oil galley taper plug
- Oil cooler bolt
- Oil return joint plug bolt

1. Insert the proper length locking wire to the bolt.
2. Twist the wire using a commercially available wire twisting tool.
3. Insert the wire in the other side hole, and twist the wire.
4. Cut off any excess wire.

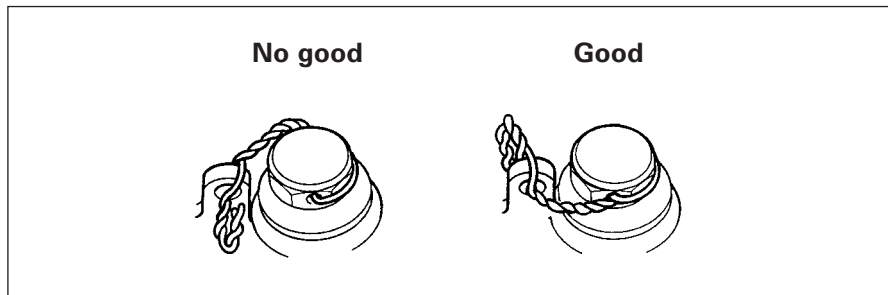
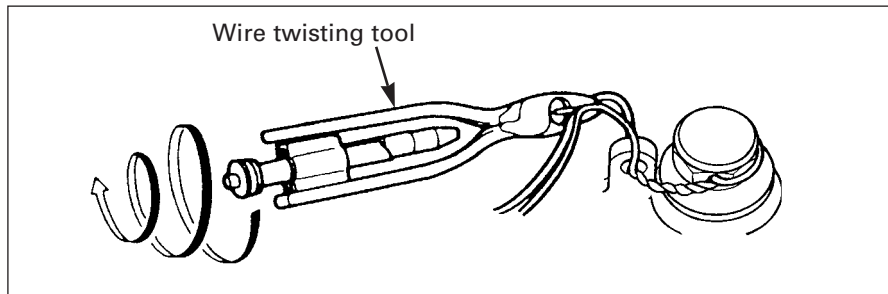

- Use new 0.8 mm (0.03 in) stainless wire.
- Secure the bolt as shown so that it cannot come loose.
- Twisting the wire too tightly will break a locking wire.

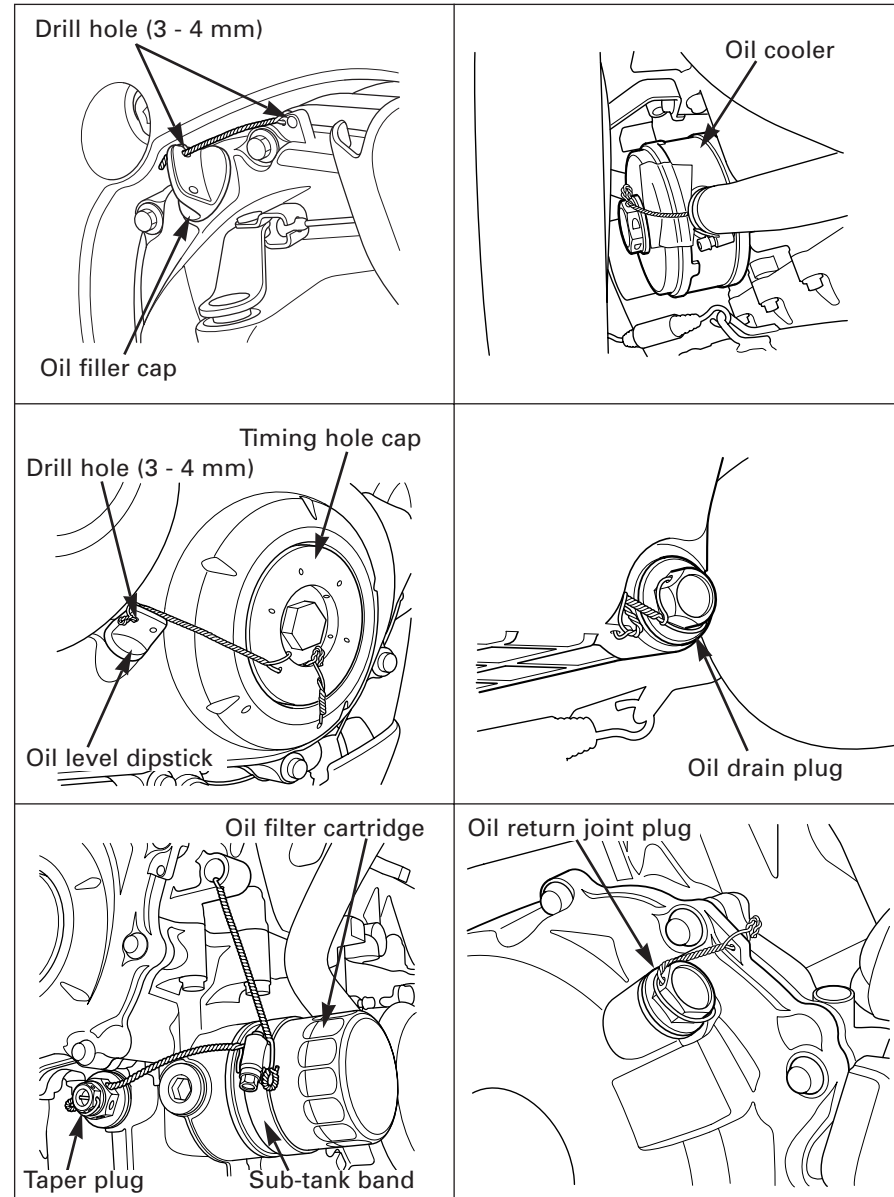

Quick Shift Kit Installation

1. Remove the gearshift pedal and pedal link.
2. Install the pedal rod sensor into the commercially available pedal link rods.
3. Connect the sensor connector to the main wire harness connector.
4. Reinstall the gearshift pedal and pedal link.

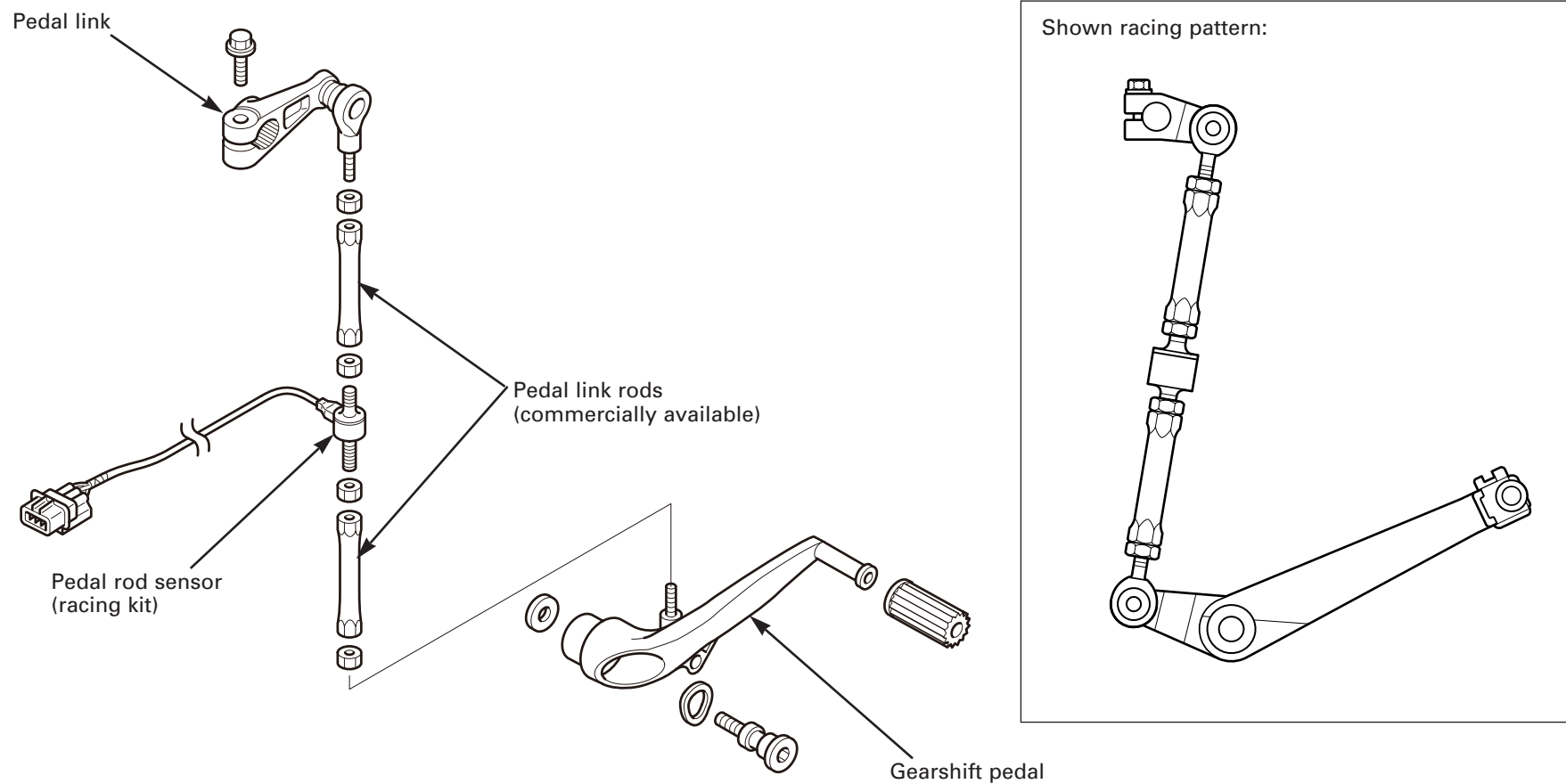

Secondary Air Supply System Removal

1. Disconnect the secondary air supply hoses from the cylinder head reed valve covers and air cleaner housing, then remove the air injection control valve.
2. Cut the removed hoses 40 mm (1.6 in) from each end of the cylinder head reed valve cover side and air cleaner housing side.
3. Install the cut hoses to the cylinder head reed valve covers, then secure them with removed clips. Install the cut hose to the air cleaner housing and secure it with removed clip.
4. Plug the hoses with cone plugs in the racing kit, and secure them with clamps also in the racing kit. Make sure the cone plugs are fastened securely.

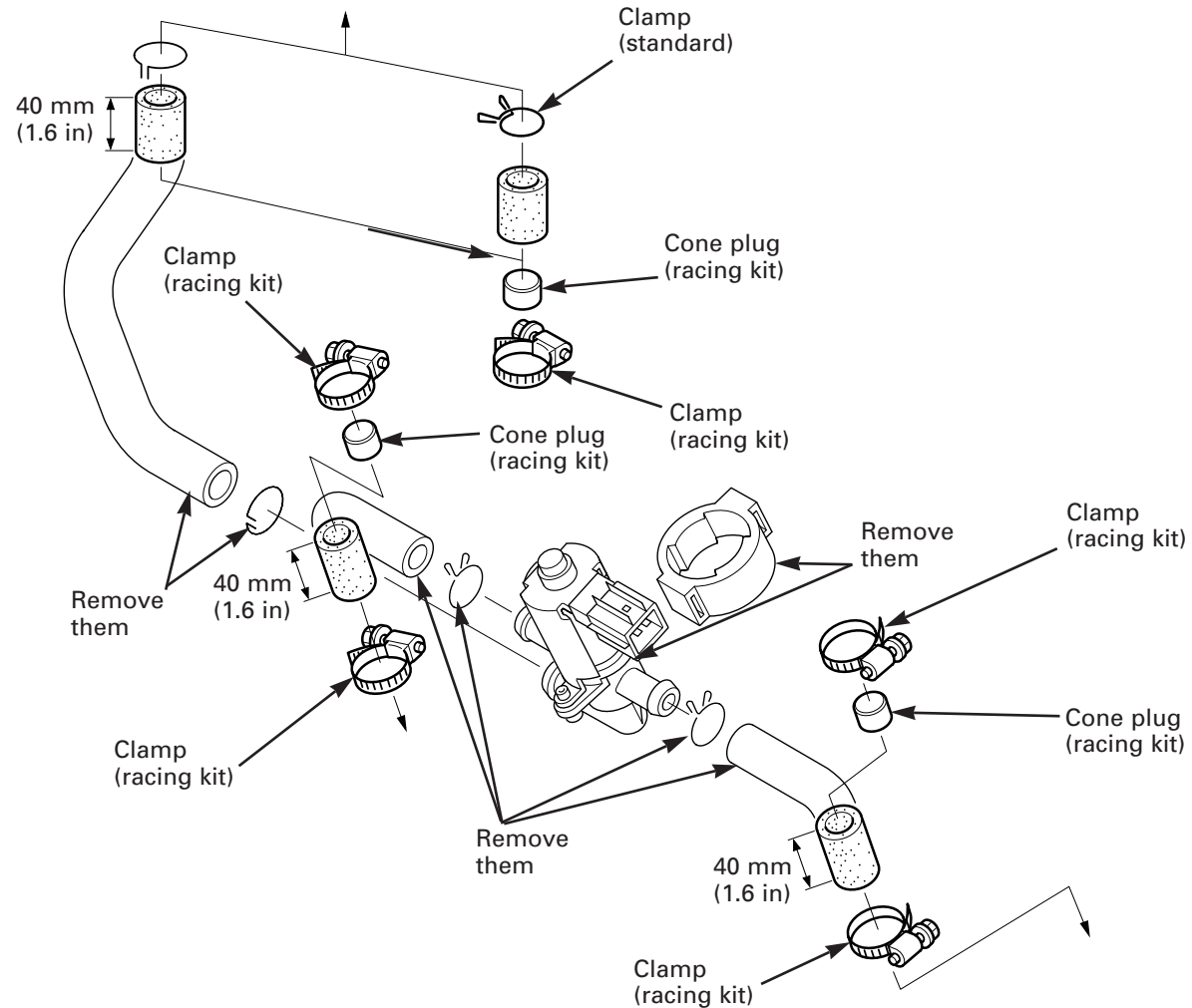

Thermostat Replacement

1. Drain the coolant.
2. Remove the thermostat housing cover, then remove the thermostat.
3. Remove the rubber from the thermostat, then install it on the thermostat in the racing kit.
4. Install the thermostat in the reverse order of removal.

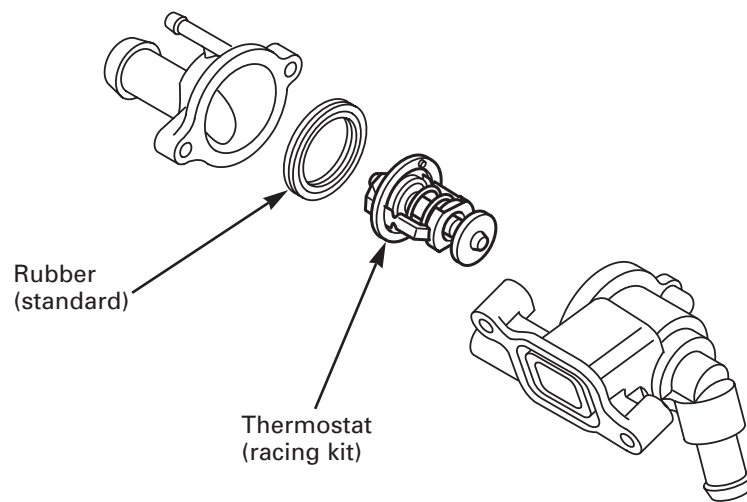

Air Bleed Hose Removal

1. Drain the coolant.
2. Disconnect the air bleed hose from the thermostat housing and the filler neck, and cut the hose 50 mm (2.0 in) on both end.
3. Install the cut hoses to the thermostat housing and filler neck and clamp them with removed clamps.
4. Install the plugs in the racing kit into the hose ends and secure them with the clamps in the racing kit.

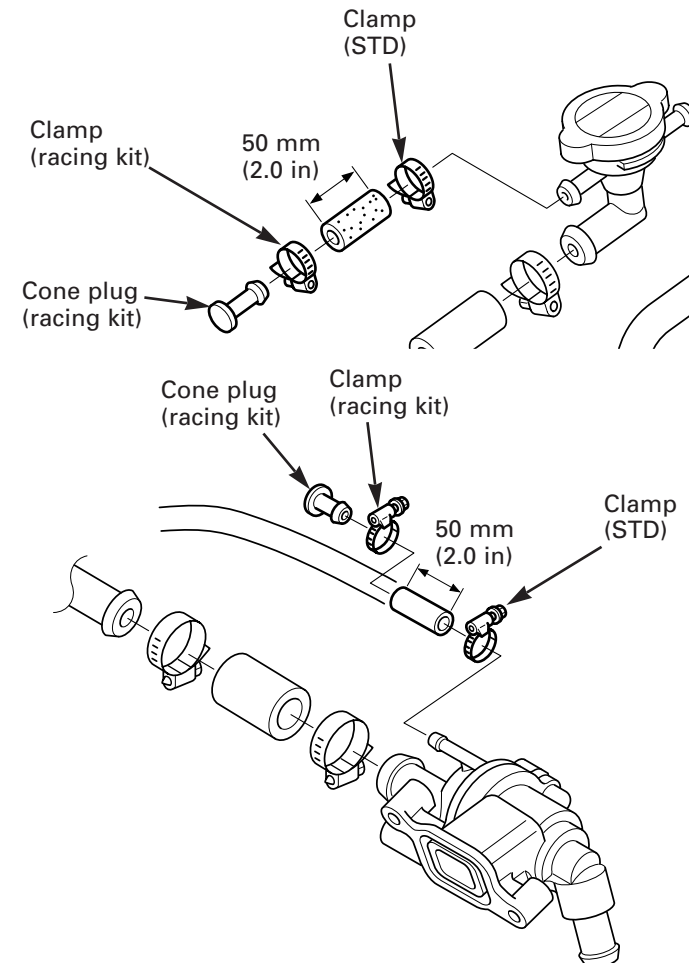

Variable Air Intake Valve Removal

1. Remove the variable air control system parts from the intake ducts.
Remove the flap valves from the inside of the intake ducts.
2. Plug the variable intake valve holes.

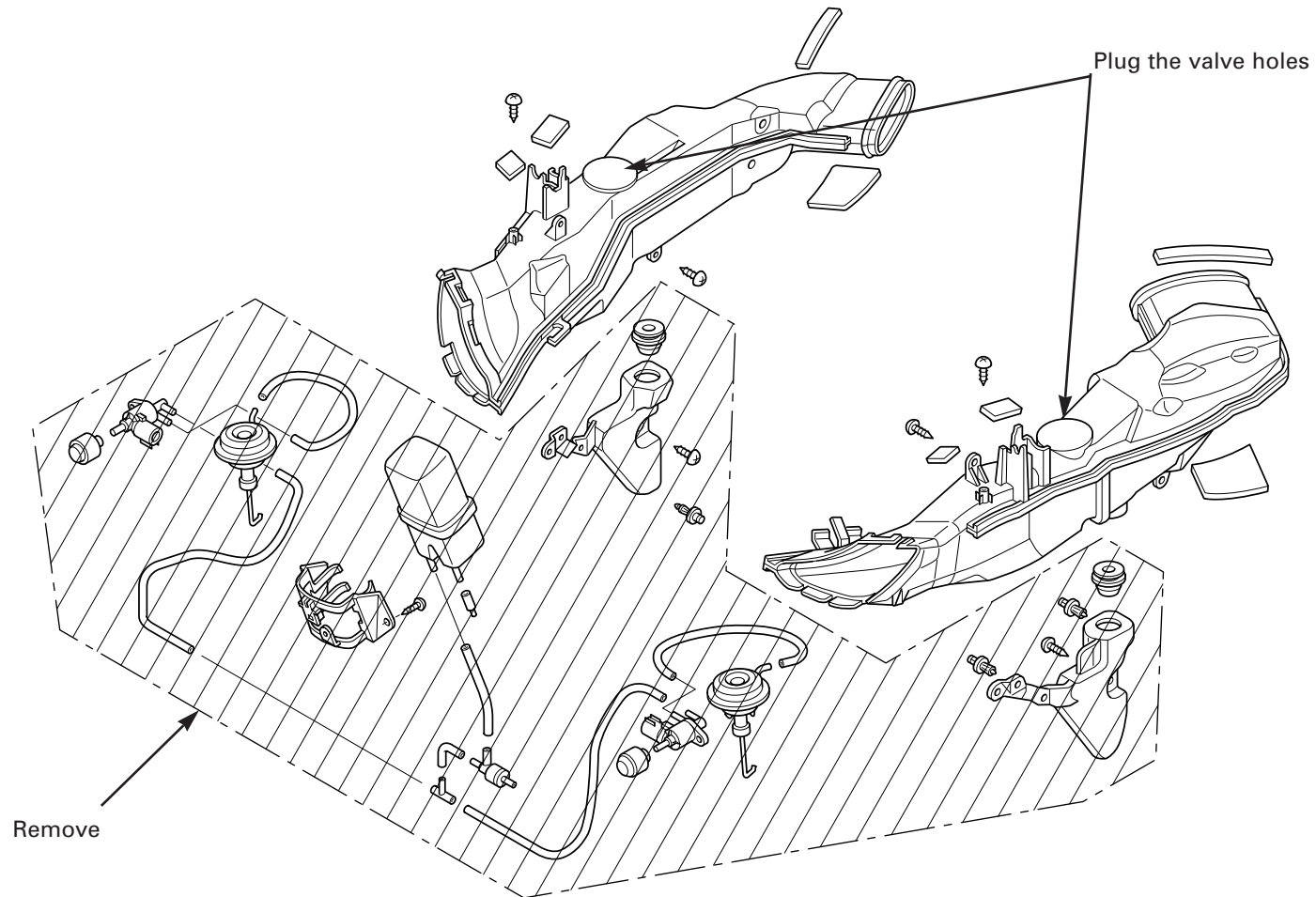

Oil Cooler Kit Installation

1. Drain the engine oil and radiator coolant.
2. Remove the standard oil cooler.
3. Install the racing kit oil cooler with a new O-ring.
4. Install the new sealing washer (standard) and oil cooler bolt (racing kit) and tighten the oil cooler bolt to the specified torque.

Torque: 59 N·m (6.0 kgf·m, 44 lbf·ft)

5. Secure the oil cooler bolt with a lock wire.
6. Replace the oil cooler hose with racing kit hoses, secure them with removed standard clamps.
7. Fill the system with recommended coolant and bleed the air. Pour recommended engine oil up to proper level.

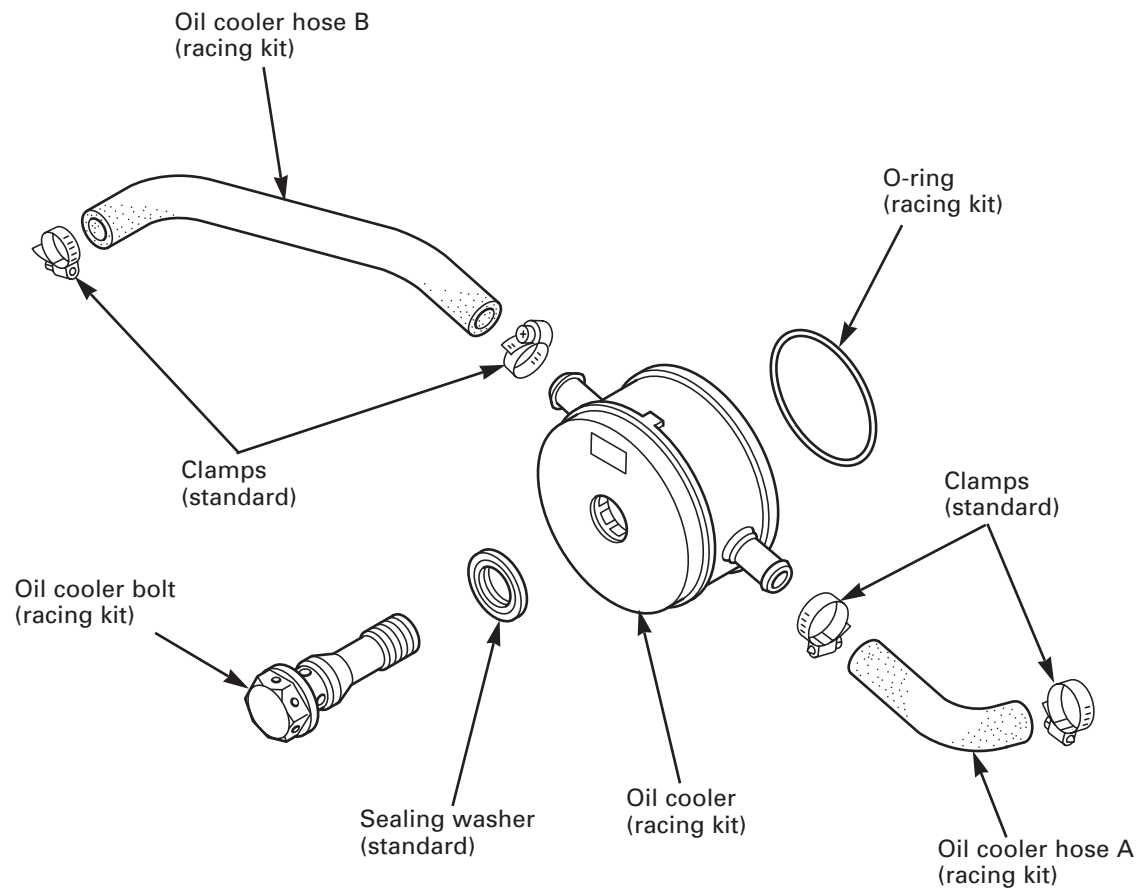

Racing Kit

Radiator Kit Installation

1. Remove the standard radiator and radiator reserve tank.
2. Cut the standard left radiator hose B as shown in the illustration below.
3. Install the racing kit radiator with the left radiator pipe and oil cooler hoses. Use standard left radiator hose B (modified), right radiator pipe/hoses and filler neck hose for racing kit radiator installation.
4. Tighten the hose clamps securely (see illustration below).
5. Secure the hose band at the water pump cover with a lock wire as shown.

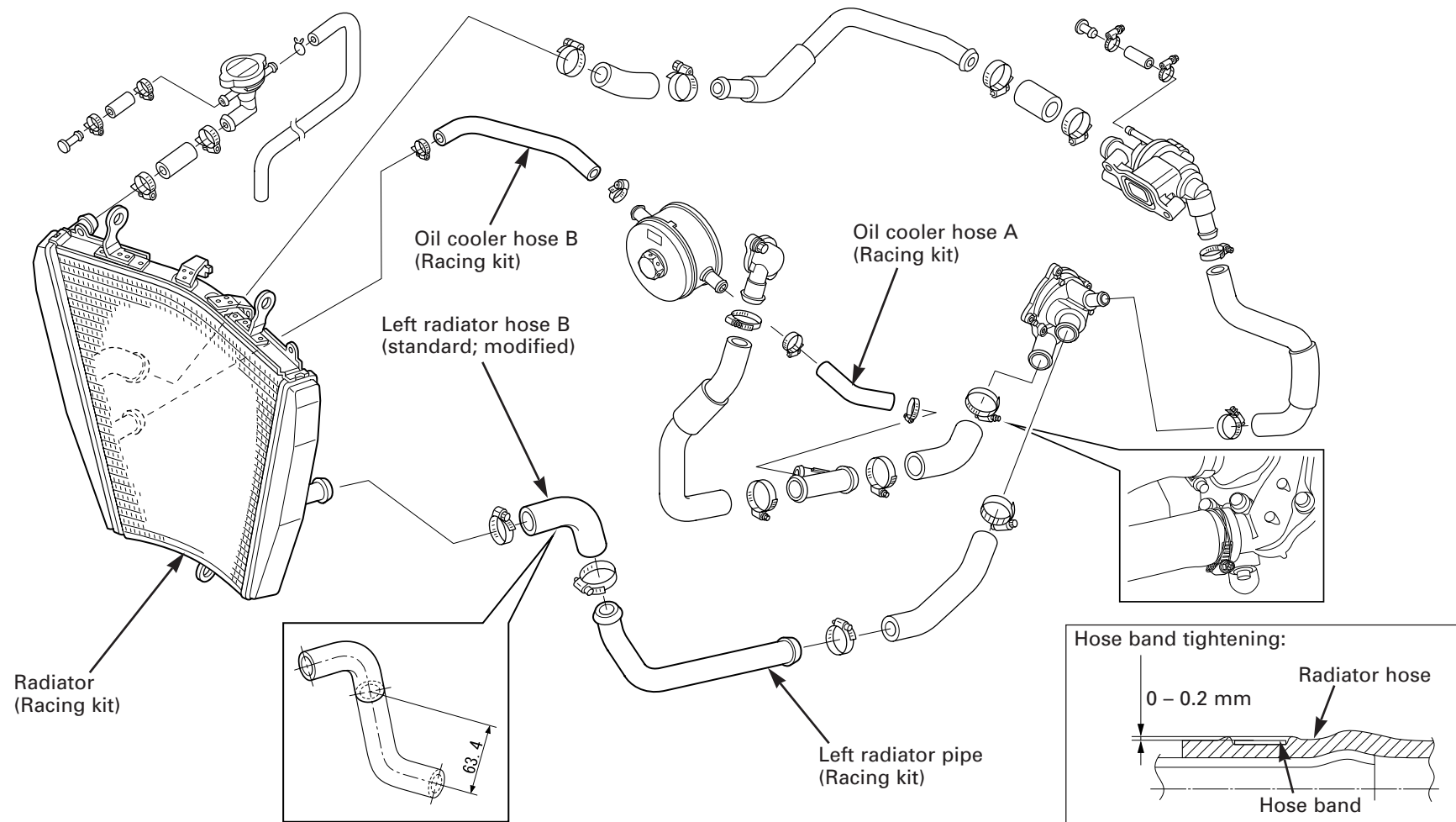

Hi Throttle Set/Engine Stop Switch Installation

1. Remove the standard throttle housing and right grip comp. from the right handlebar.
2. Install the racing kit throttle pipe onto the right handlebar.
3. Grind off the boss in the upper throttle housing as shown.

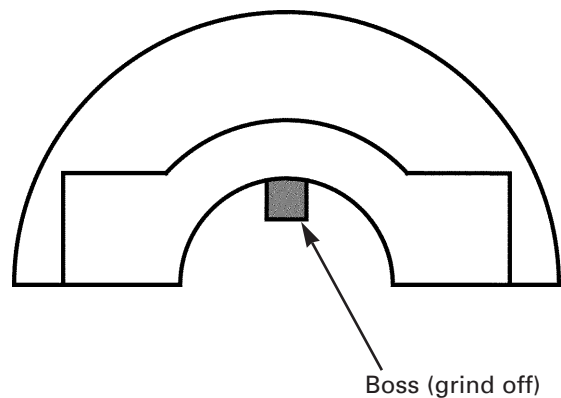

4. Install racing kit throttle cables A and B to the under throttle housing.
5. Connect the throttle cable ends to the throttle pipe, then tighten the throttle housing screws.
6. Install the racing kit starter/engine stop switch to the right handlebar. Tighten the forward screw first, then the rear screw.

Note:

- Do not overtighten the throttle housing screw, so the starter switch hard to return.
 - If the starter switch position is moved on the handlebar, tape around the handlebar.
 - Check the inside of the throttle housing and remove moisture completely after riding in rain.
7. Connect the starter/engine stop switch 8P (White) connector to the wire harness.

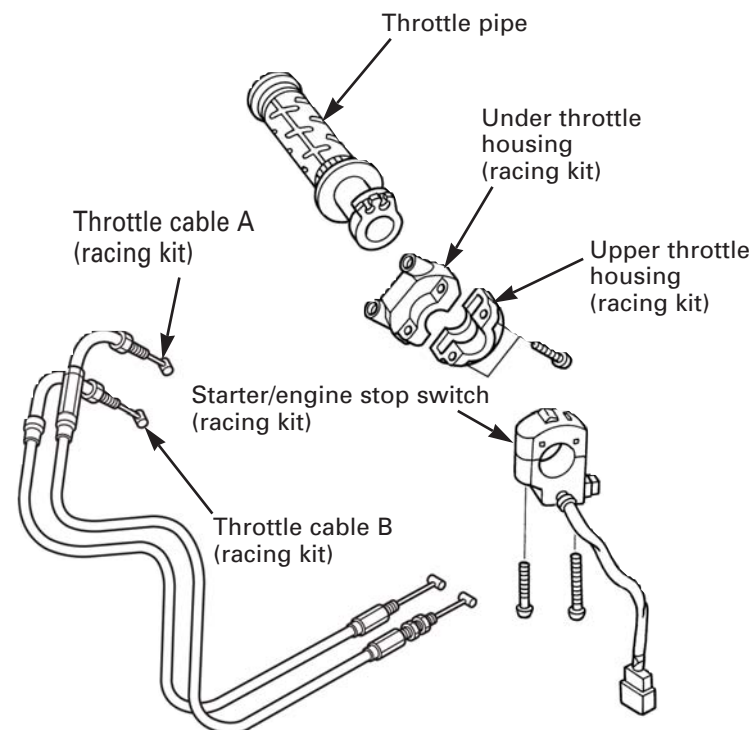

Racing Kit

Breather Case Installation

1. Disconnect the crankcase breather hose from the air cleaner housing and cylinder head cover, then remove the breather hose.
2. Install the breather hose, return hose and drain hose in the racing kit to the breather case, and tighten the clamp screws securely.
3. Attach rubber pieces between the tabs of the breather case and frame.
4. Install the breather case assembly into the frame (the place previously installed the EVAP PAIR control valve), tighten the bolts and nuts securely.
5. Connect the breather hose to the cylinder head cover and secure it with clamp in the racing kit.
6. Connect the breather return hose to the air cleaner housing and secure them with standard clip.
7. Install the plug in the racing kit into the drain hose end, secure it with the clamp in the racing kit.

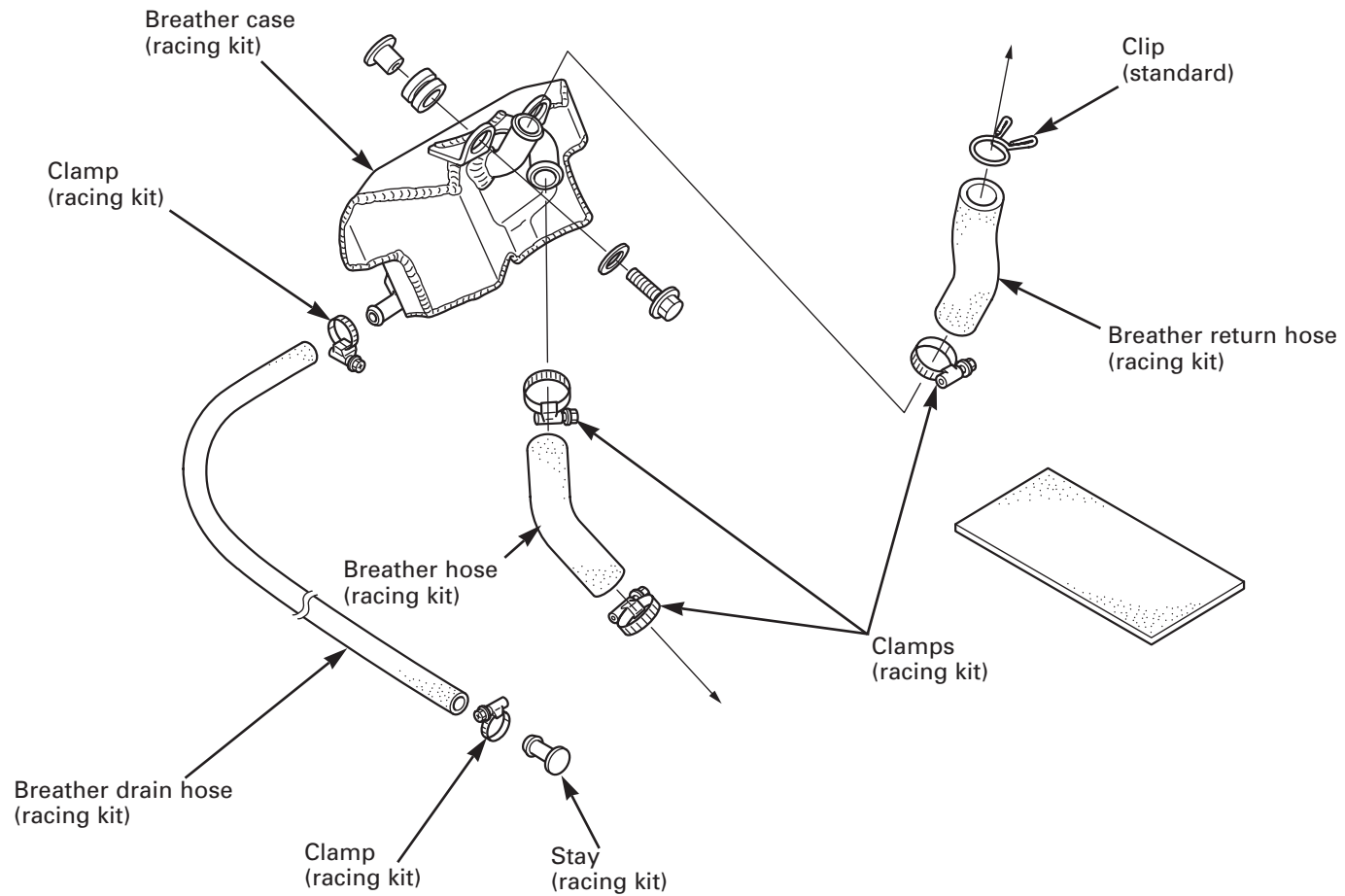

Air Funnel Replacement

1. Remove the original air cleaner element and air funnels.
2. Install the racing kit air funnels into their proper locations according to each identification mark on the funnel.
3. Install and tighten the bolts securely.
4. Wire lock the bolts using the bolt groove.

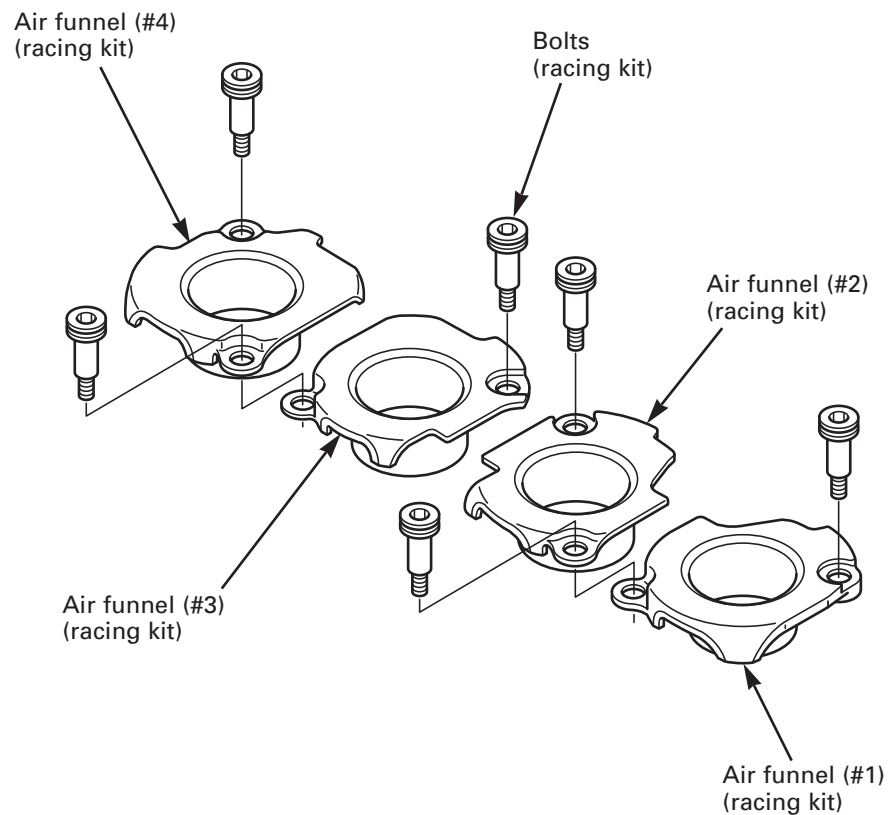

Secure the air funnel bolts with wire to prevent them from into the cylinder.

1. Put the wire around the bolt groove.
2. Twist the wire and tighten the bolt.
3. Put the wire around the other bolt groove.
4. Twist the wire and tighten the bolt.

- Route the twisted wire under the air funnel as shown.

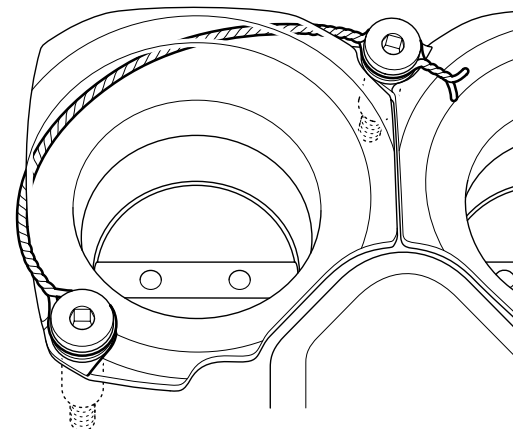

Replace the air cleaner element retaining screw to the 5 x 8 mm flange bolt and make a drill hole for the wire lock. Install the retainer and tighten the bolt. Secure the bolt with lock wire as shown.

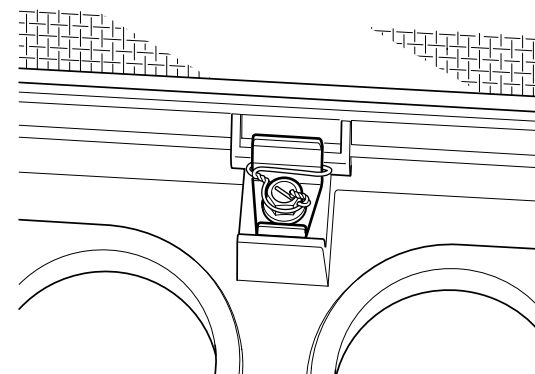

Racing Kit

Steering Damper Replacement

1. Remove the standard steering damper cover and steering damper.
2. Install the racing kit steering damper using the racing kit shelter stay and damper stay without installing the covers.

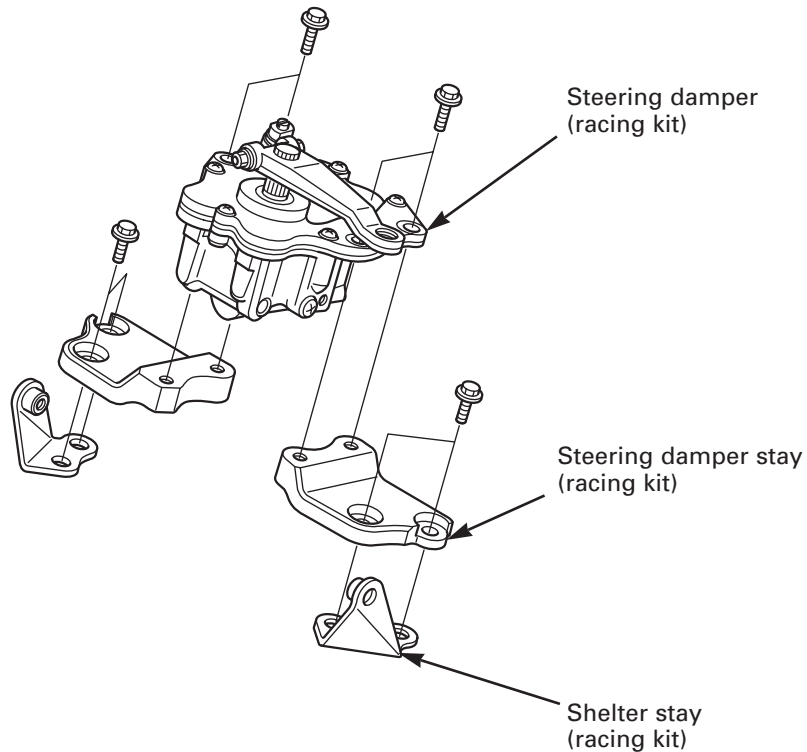

- On the racing kit mechanical steering damper, the damping force is adjusted by with a screwdriver. We recommend drilling a hole in the top shelter to allow steering damper adjustment without removing the shelter.
- For adjustment only, drill a $\varnothing 8$ mm hole. For the reading indicator label, drill a $\varnothing 18$ mm hole.

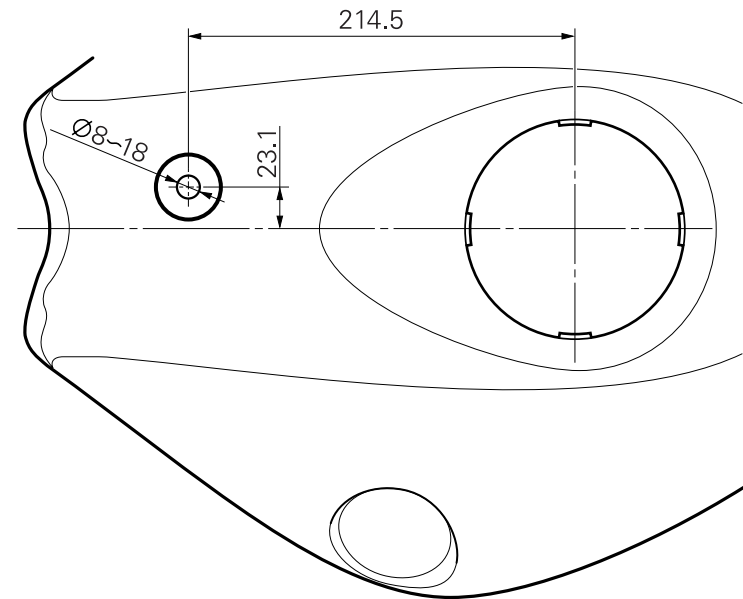

NOTICE

- Do not use racing kit steering damper with standard top bridge. The racing kit steering damper must be used with racing kit stays.
- When the racing kit steering damper is installed (2P Black connector is disconnected), the warning LED on the combination meter is illuminated but there are no problem in the system.
- When using the standard HESD, the unit can be set by using a PC.

Steering Stem Modifying

1. Make the steering stopper pieces from aluminium block. The piece dimensions are shown in the illustration below.

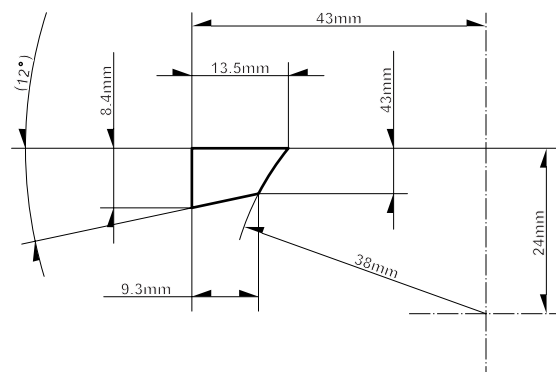

2. Weld the stopper pieces onto the bottom bridge as shown.
3. Make sure the steer angle is minimum of 15° on both side.

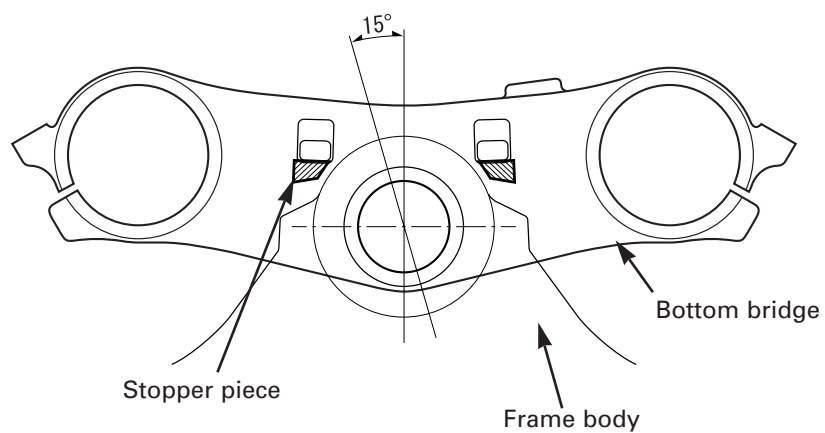

Throttle Body Replacement

Replace the throttle body with the racing kit.

NOTE:

- The 2008 CBR1000RR is equipped with IACV (Idle Air Control Valve). Fundamentally IACV controls the air volume under the low engine speed range. But the throttle body of the racing kit, IACV controls the air volume under all engine speed range to optimize the throttle control. This intends to reduce the engine brake feeling under high engine speed.
- Please use the HRC kit PGM-FI/IGN unit for the throttle body of the racing kit.

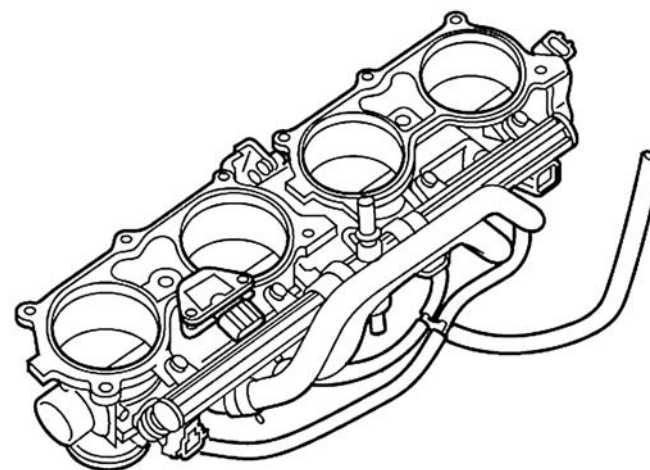

Fuel Feed Hose Removal/Installation

The fuel hose retainer must be replaced, if the fuel feed hose is disconnected.

Removal

1. Turn the engine stop switch OFF.
2. Lift the fuel tank and support it.
3. Disconnect the fuel pump 2P (Brown) connector.
4. Turn the engine stop switch ON and start the engine. Operate the engine at idle until the engine stalls.
5. Turn the engine stop switch OFF, disconnect the battery ground (-) cable.
6. Check the fuel feed hose quick connector for dirt,, clean if necessary. Cover the quick connector with a shop towel or an equivalent.

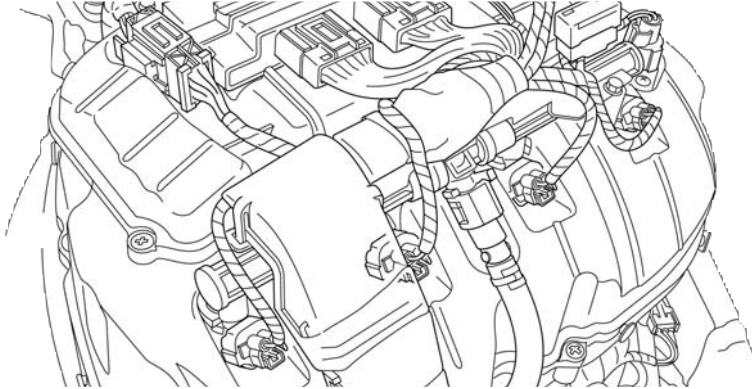

7. Pull the rubber cap and remove it from the retainer.
8. Hold the connector by one hand and push the retainer tabs with the other hand, then remove it from the lock groove. Disconnect the connector, and remove the retainer and rubber cap from the joint.
9. After the fuel feed hose is removed, cover the joint portion to avoid entering the dust and dirt into the fuel line.

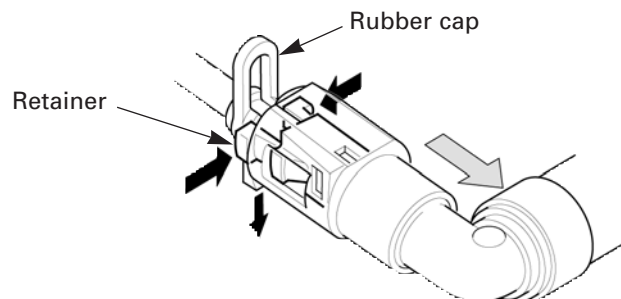

Installation

1. Install the new retainer into the fuel feed hose joint as shown.
2. Check the rubber cap condition, replace it if it is damaged. Install the rubber cap onto the fuel pipe as shown in the illustration.
3. Check that the retainer tabs align with the connector grooves, then install the fuel feed hose to the fuel pipe until it clicks. If it is hard to install, apply a small amount of engine oil to the tip of the fuel pipe.

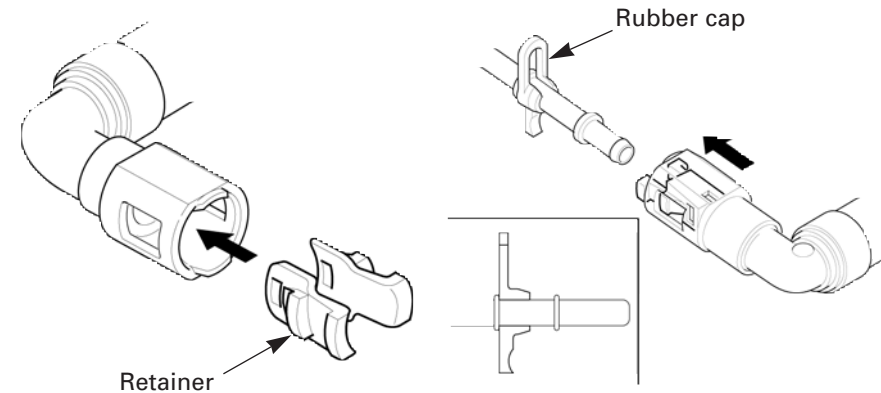

4. Move the fuel feed hose connector back and force, check that the fuel feed hose connector is securely connected.
5. Check that the rubber cap is installed securely between the pipe flange and retainer.
6. Connect the pump connector and battery negative (-) cable. Turn the engine stop switch ON and operate the fuel pump about 2 seconds. Repeat this procedure 2 - 3 times and check that there are no fuel leaks. If there are fuel leaks, replace the fuel feed hose with a new one.

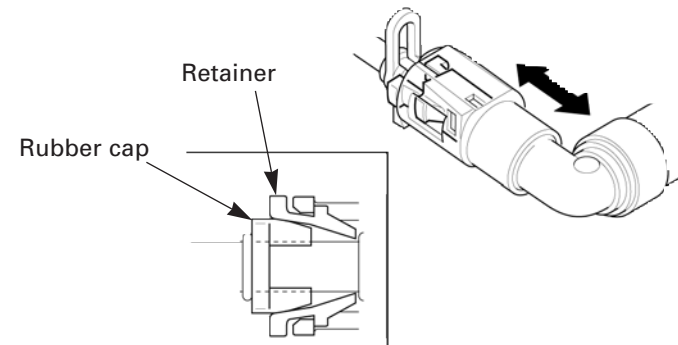

Fuel Pump Kit Installation

1. Remove the standard fuel tank, and then remove the nuts, setting plate, outer seal, fuel pump and pump packing.

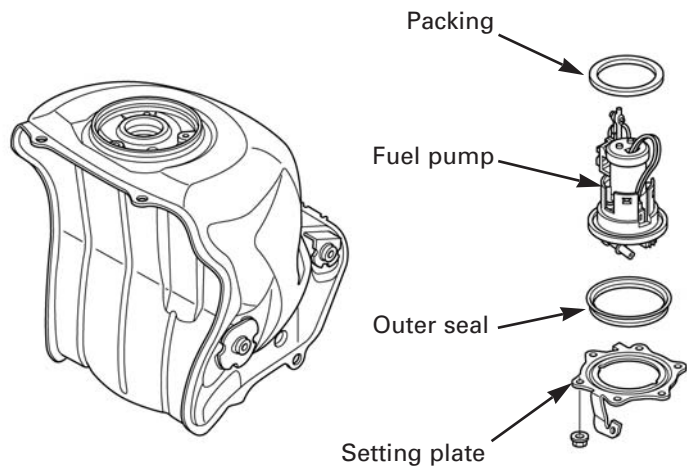

2. Install the racing kit spacer packing to the fuel tank.
Note the direction of the spacer packing.
3. Install the racing kit fuel pump spacer. Install the removed fuel pump setting plate nuts and tighten the nuts securely.

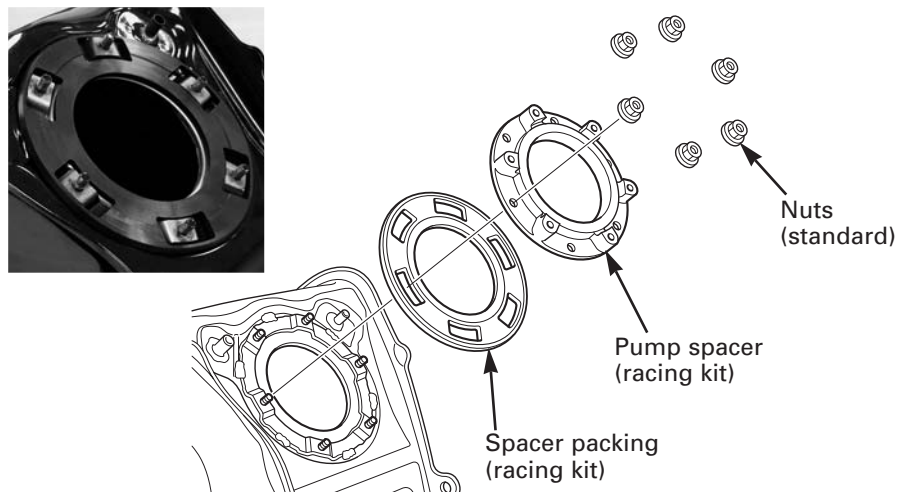

4. Install the new fuel pump packing.
5. Install the fuel pump rubber in the racing kit aligning its tabs with the grooves in the fuel pump.

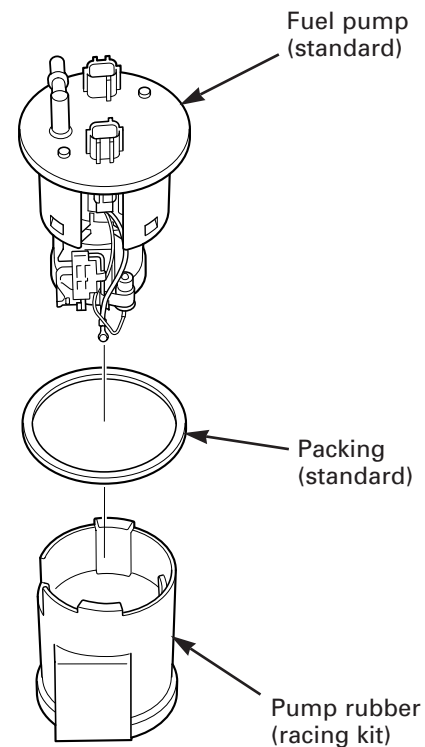

Racing Kit

6. Install the fuel pump assembly into the fuel tank.
7. Install a new outer seal onto the fuel pump spacer.
Install the racing kit fuel pump setting plate onto the spacer with its "FR" mark facing forward.

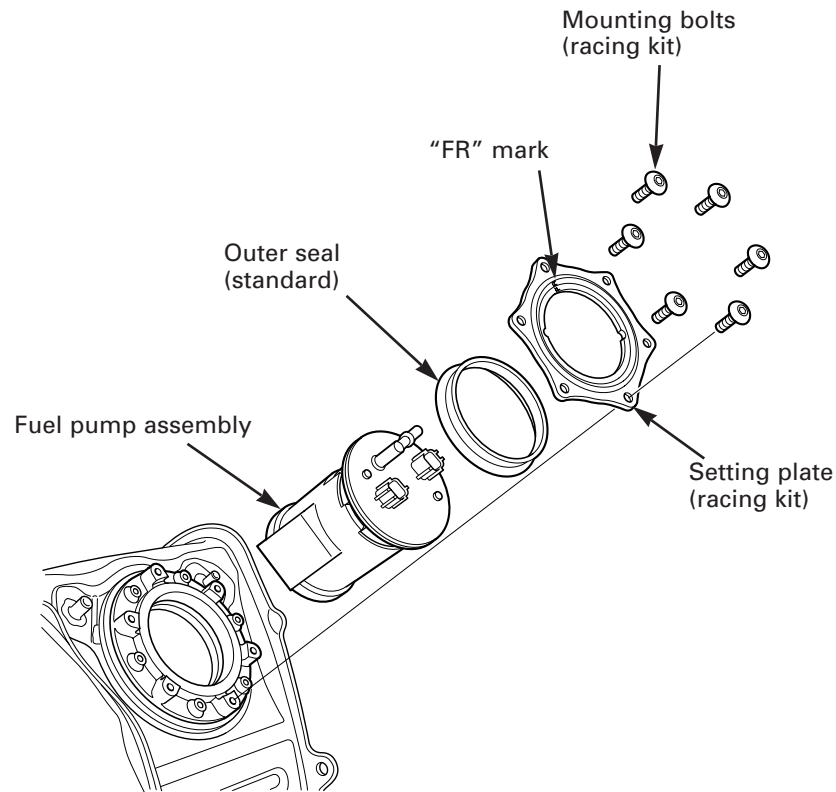

8. Adjust the fuel pump direction as shown. Install the setting plate mounting nuts securely.

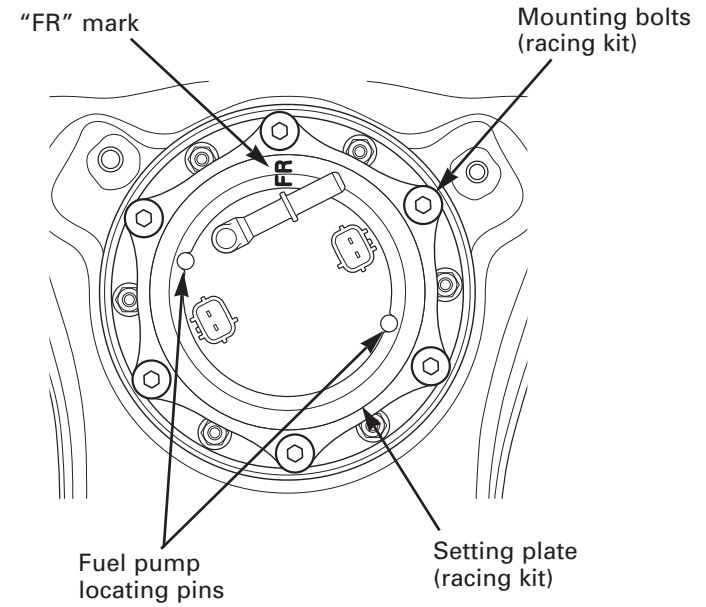

9. Install the fuel tank onto the vehicle. Route the fuel tank breather hose properly and connect it to the fuel tank.

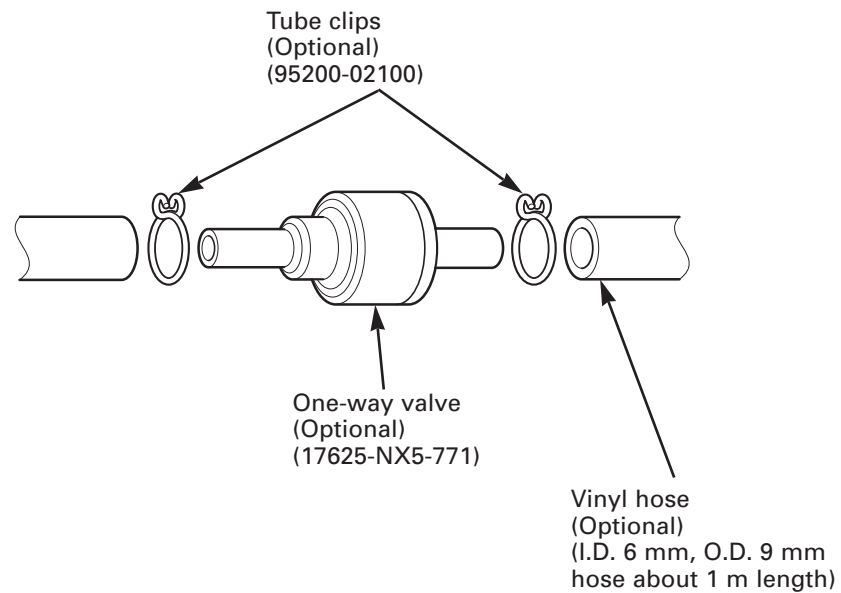
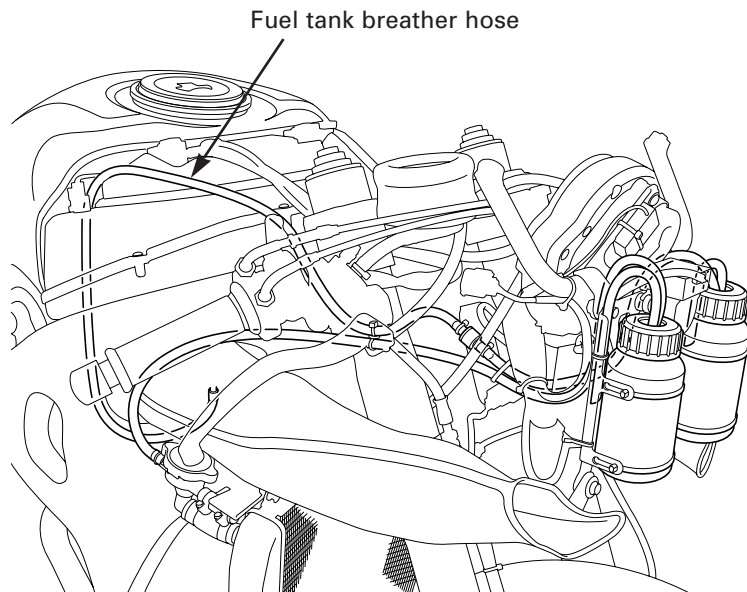

Racing Kit

Bank Angle Sensor Installation

1. Remove the standard upper cowl stay and install the racing kit upper cowl stay.
2. Install the racing kit combination meter onto the upper cowl stay.
3. Install the racing kit bank angle sensor to the racing kit catch tank stay using screw/washers, collars and flange nuts as shown.
4. Install the catch tank stay onto the upper cowl stay and secure it bolts and nuts.
5. Install the catch tanks and secure them with tie-laps.

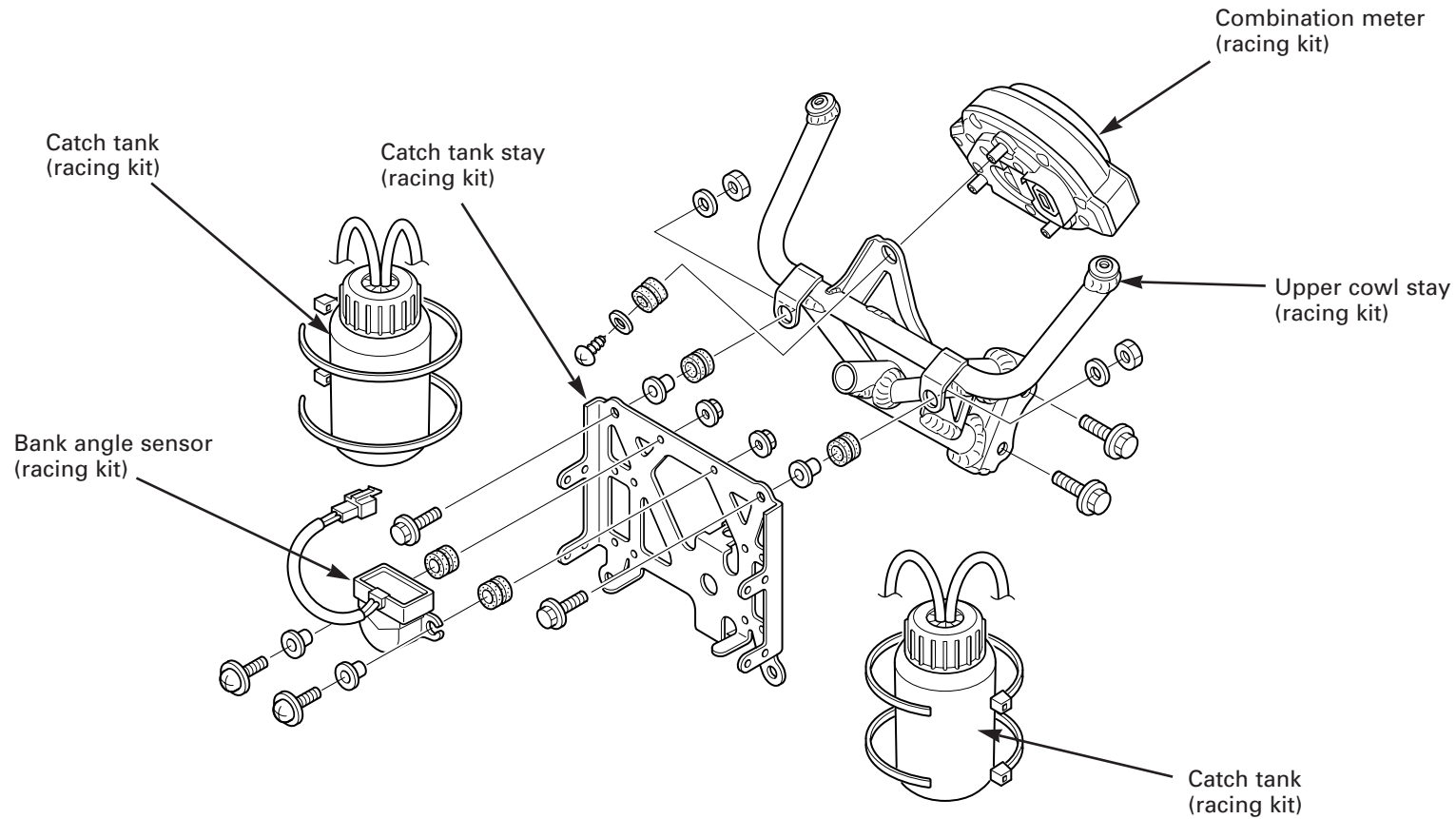

Seat Rail Replacement/Battery Tray Installation

1. Remove the original rear fender B and seat rail.
2. Install the racing kit seat rail onto the frame, and tighten the mounting bolts to the specified torque.

Torque: 39 N·m (4.0 kgf·m, 29 lbf·ft)

3. Install and tighten the fuel tank pivot bolt to the specified torque.

Torque: 9 N·m (0.9 kgf·m, 6.5 lbf·ft)

4. Install the rubber cushion/battery tray (racing kit) and rear shock absorber adjuster plate (racing kit) onto the seat rail and secure them with mounting bolts.
5. Install the starter relay (racing kit) to the battery tray.
6. Replace the starter/ground cable to the racing kit.
7. Remove the harness tape and separate the starter cable and ground cable.
8. Route the wire harness, battery cable (racing kit) and ground cable (racing kit), then connect them to the battery and starter relay.

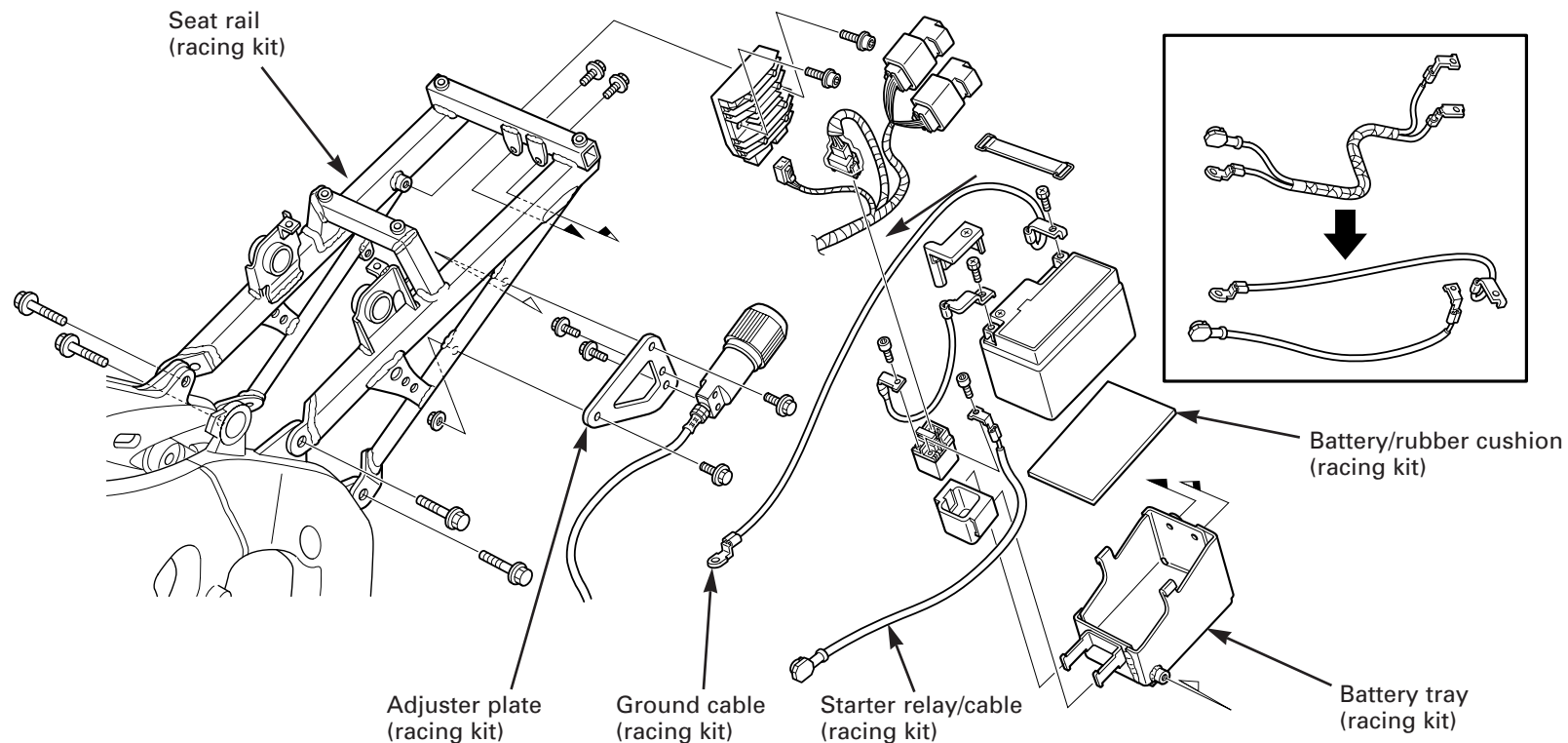

Racing Kit

Exhaust Pipe/Muffler Replacement

Remove the muffler and exhaust pipe (see Shop Manual).
Remove the exhaust pipe stud bolts using the 7 mm nuts in the racing kit.

Install the racing kit exhaust pipe and muffler as shown.

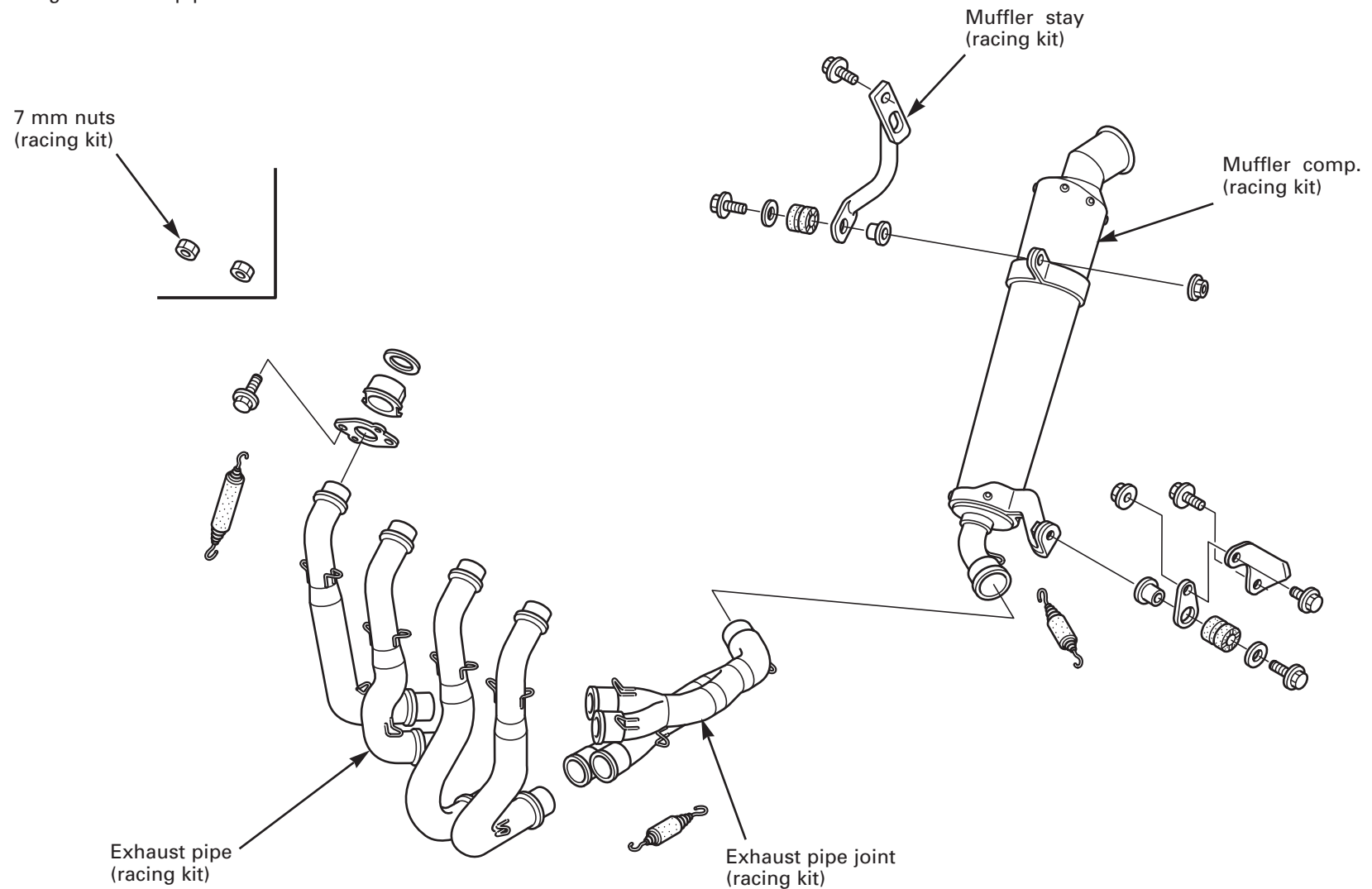

Drive Chain Guard Installation

NOTICE

Inside of the swingarm is filled with urethane foam. Do not weld the drive chain guard because the urethane foam will burn.

1. Remove the swingarm. Drill $\varnothing 9.05 - 9.25$ mm holes for the pop nut as shown.

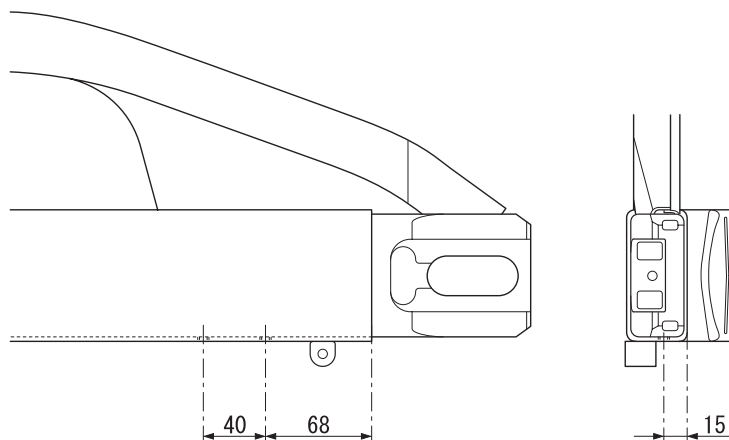

2. Apply adhesive to the drill holes and pop nut seat, and install the pop nuts into the holes. Stake the pop nuts using a commercially available tool.

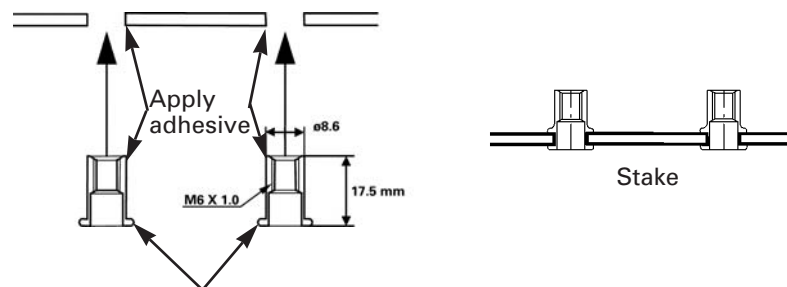

Pop nut, 6 mm
(manufactured by POP RIVET FASTENER LTD.; SPH650R or equivalent)

3. After the adhesive hardens, install the washer and drive chain guard and washers, tighten the bolts securely.

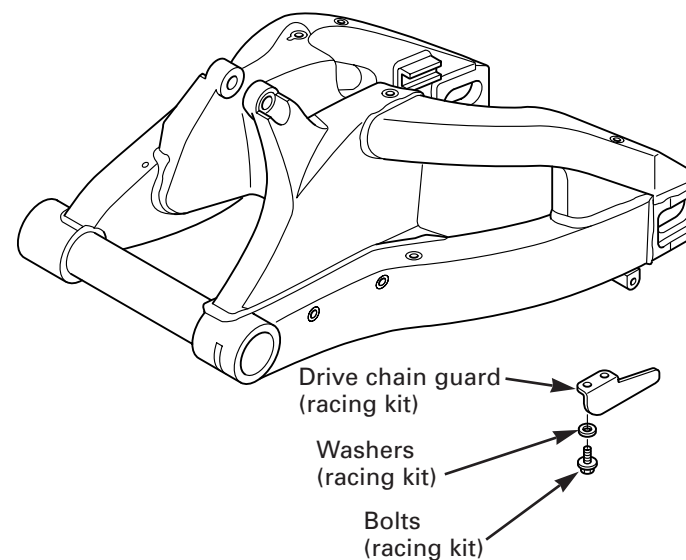

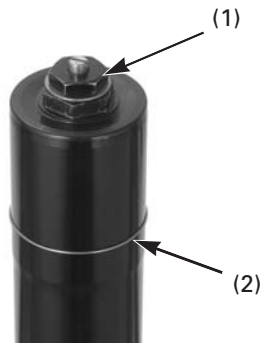

(1) PRE-LOAD ADJUSTER
(2) STOPPER RING



Fork Spring Replacement

Make sure that the pre-load adjuster is on the softest position by turning the adjuster counterclockwise.
 Make sure that the rebound adjuster is on the softest position.
 Remove the stopper ring from the fork slider.
 Remove the fork bolt from the fork slider.
 Push the fork slider slowly down, and gently seat the dust seal onto the axle holder.

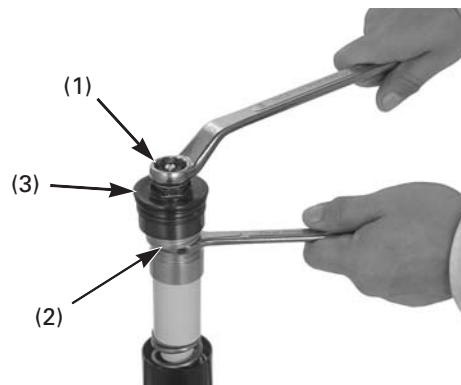

(1) DAMPER ROD ADJUST CASE
(2) LOCK NUT (3) FORK BOLT

Insert a 14 mm spanner between spring collar B and the spring seat stopper, and hold the damper rod lock nut.
 Hold the pre-load adjuster, then loosen the lock nut.
 Loosen the fork bolt assembly, then remove it from the damper rod.

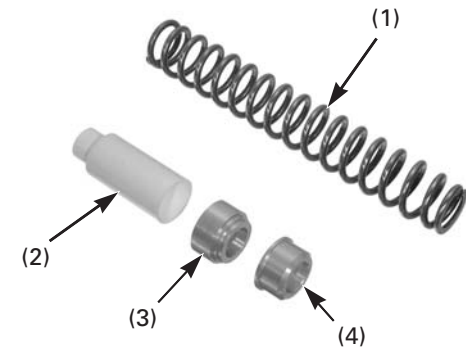

(1) FORK SPRING (2) SPRING COLLAR
(3) SPRING SEAT STOPPER
(4) SPRING COLLAR B

Remove the following:

- Spring collar B
- Spring seat stopper
- Spring collar
- Fork spring

The following optional fork springs are available.

Part number	Spring rate	Oil level
51401-NL9-901	8.8 N/mm (K=0.90)	83 mm
51401-MEL-R31	9.3 N/mm (K=0.95)	86 mm
51402-NL9-901	9.8 N/mm (K=1.00)	87 mm
51401-NL9-711	10.5 N/mm (K=1.05)	86 mm
51402-NL9-711	10.8 N/mm (K=1.10)	92 mm

Optional springs are identified by the spring rate letter on the spring end as shown.

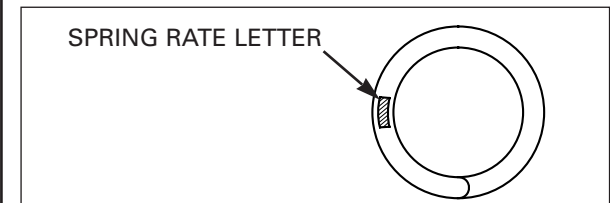

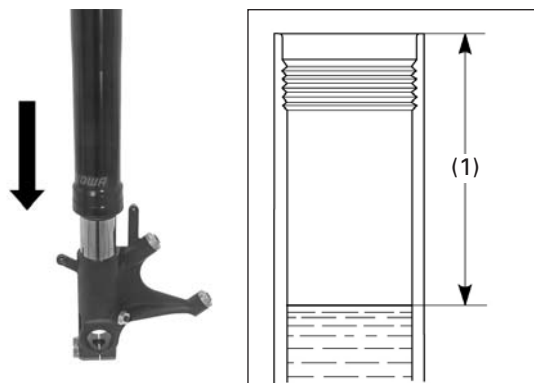

(1) OIL LEVEL

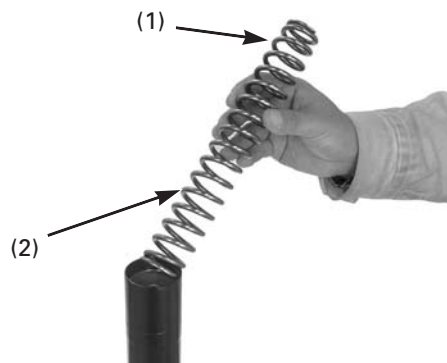

(1) TAPERED END
(2) FORK SPRING

Slowly lower the slider, and gently seat the dust seal onto the axle holder and leave it for 5 minutes.

After the oil level stabilizes, measure the oil level from the top of the fork slider. Be sure the oil level is the same in the both forks.

Install the fork spring into the fork slider with the tapered end facing up.

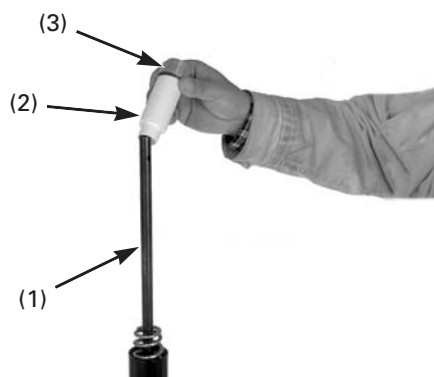

(1) DAMPER ROD HOLDER
(2) SPRING COLLAR
(3) SPRING SEAT STOPPER

Extend the fork damper fully and install the damper rod holder onto the damper rod adjust case.

Tool:
Damper rod holder **070MF-MBZC120**

Install the spring collar and spring seat stopper.

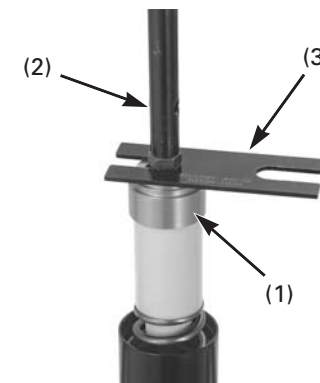

(1) SPRING SEAT STOPPER
(2) DAMPER ROD HOLDER
(3) STOPPER PLATE

Install the stopper plate under the damper rod lock nut, while compress the fork spring by pushing the spring seat stopper and pulling the damper rod with a damper rod holder.

Tool:
Stopper plate **070MF-MBZC130**

Remove the damper rod holder.

Racing Kit

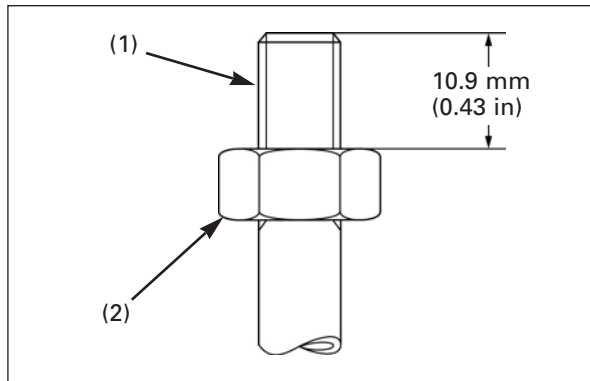

(1) DAMPER ROD
(2) LOCK NUT

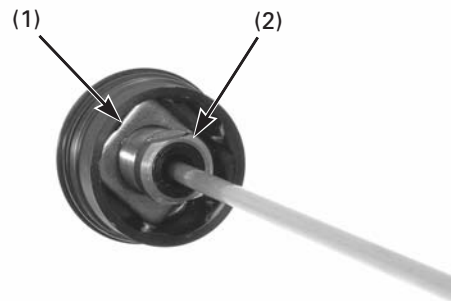

(1) PRE-LOAD ADJUST PLATE
(2) DAMPER ROD ADJUST CASE

Make sure the distance between the damper rod end and upper surface of the lock nut is 10.9 mm (0.43 in).

Turn the pre-load adjust plate clockwise until it seats lightly.

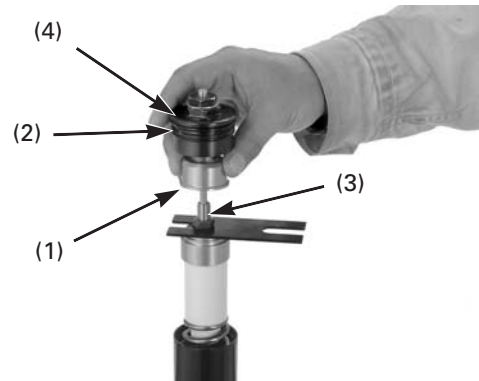

(1) SPRING COLLAR B
(2) NEW O-RING
(3) DAMPER ROD (4) FORK BOLT

Install the spring collar B with its flange side facing down.
Apply fork fluid to new O-rings and install them to the fork bolt.
Install the fork bolt to the damper rod.
Screw the fork bolt until the adjust case contacts the lock nut.

Remove the stopper plate tool.

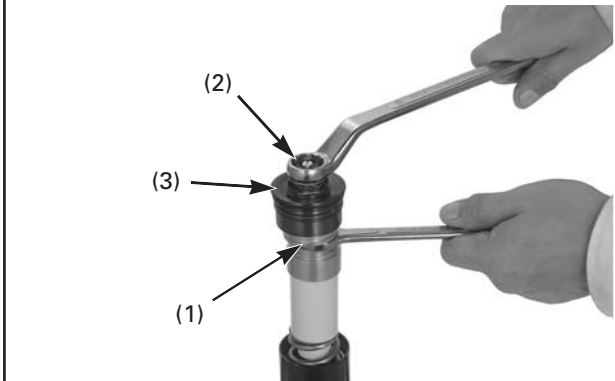

(1) LOCK NUT
(2) DAMPER ROD ADJUST CASE
(3) FORK BOLT

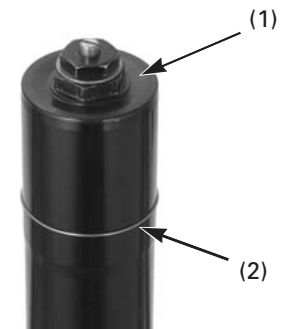

(1) FORK BOLT
(2) STOPPER RING

Insert a 14 mm spanner between spring collar B and the spring seat stopper, and hold the damper rod lock nut. Hold the damper rod adjust case, then tighten the lock nut to the specified torque.

Torque: 20 N·m (2.0 kgf·m, 14 lbf·ft)

Remove the 14 mm spanner from the damper rod lock nut. Install the fork bolt to the fork slider.
Install the stopper ring.



(1) PRE-LOAD ADJUSTER

Front Suspension Setting

Front Suspension Setting

Pre-load Adjuster

Spring pre-load can be adjusted by turning the pre-load adjuster.

Turn the adjuster clockwise, the spring pre-load increases.

Turn the adjuster counterclockwise, the spring pre-load decreases.

Standard position: 6 turns in from full soft

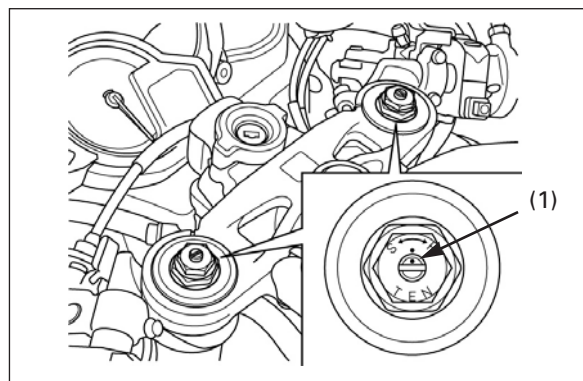

(1) REBOUND ADJUSTER

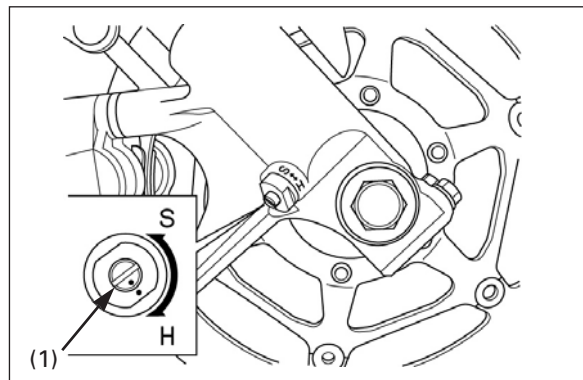

(1) COMPRESSION ADJUSTER

Rebound Damping Adjuster

Turn the rebound damping adjuster clockwise until it stops (full hard position), then turn the adjuster counterclockwise.

Standard position: 2.25 turns out from full hard

Compression Damping Adjuster

Turn the compression damping adjuster clockwise until it stops (full hard position), then turn the adjuster counterclockwise.

Standard position: 2 turns out from full hard

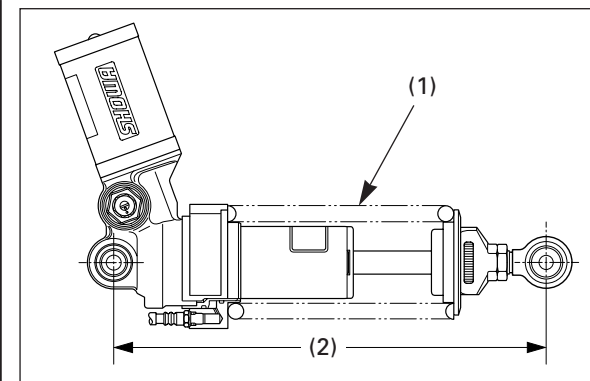

(1) SPRING
(2) STANDARD LENGTH (L=305 mm)

Rear Shock Absorber Spring

Six optional rear shock absorber springs are available.

Part number	Spring rate	Identification color
52401-NL9-901	93.2 N/mm (K=9.5)	Blue
52401-MEL-R11	98.1 N/mm (K=10.0)	Red
52402-NL9-901	103.0 N/mm (K=10.5)	White
52403-NL9-901	108.0 N/mm (K=11.0)	Black
52404-NL9-901	113.0 N/mm (K=11.5)	Green
52405-NL9-901	118.0 N/mm (K=12.0)	Sliver

The optional rear shock absorber springs are identified by color.

Racing Kit

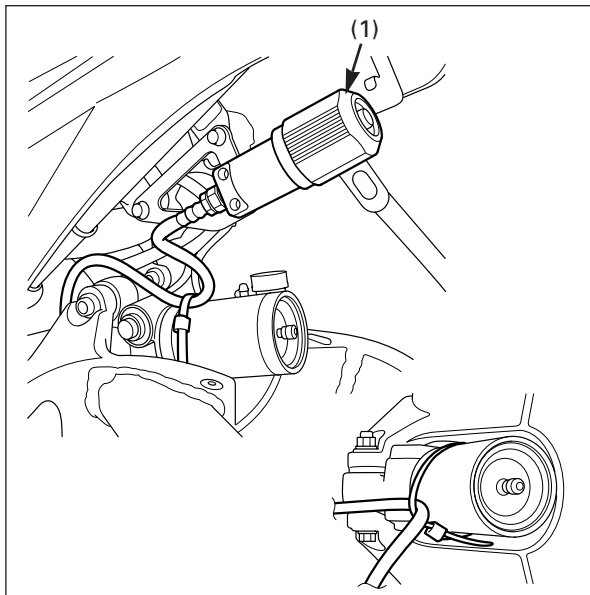

(1) PRE-LOAD ADJUSTING KNOB

Rear Suspension Setting

Pre-load Adjuster

Spring pre-load can be adjusted by turning the pre-load adjuster knob on the seat rail. Turn the adjuster clockwise, the spring pre-load increases.

Turn the adjuster counterclockwise, the spring pre-load decreases.

Standard position: 20 clicks in from full soft

When installing the racing kit rear shock absorber, route the pre-load adjuster hose properly referring to the illustration above.

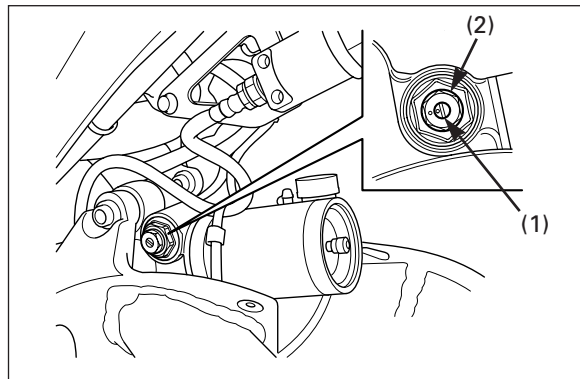

(1) COMPRESSION DAMPING ADJUSTER (Lo)
(2) COMPRESSION DAMPING ADJUSTER (Hi)

Hi-speed Compression Damping Adjuster

Turn the hi-speed compression damping adjuster counterclockwise until it stops (full soft position), then turn the adjuster clockwise.

Standard position: 2 ± 0.25 turns in from full soft

Low-speed Compression Damping Adjuster

Turn the low-speed compression damping adjuster clockwise until it stops (full hard position), then turn the adjuster counterclockwise.

Standard position: 10 clicks out from full hard

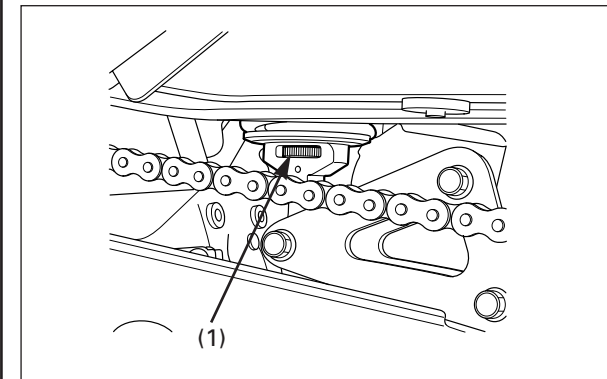

(1) REBOUND DAMPING ADJUSTER

Rebound Damping Adjuster

Turn the rebound damping adjuster clockwise until it stops (full hard position), then turn the adjuster counterclockwise.

Standard position: 8 clicks out from full hard

Optional Front Wheel

Refer to following chart for optional front wheel, fork and brake disc combinations.

No.	Part Number	Item	Fork	STD	STD	Showa SP
			Brake disc Wheel Q'ty	KIT STD	Brembo NL9	Brembo NL9
		Wheel side collar				
1	44311-NL9-710	Collar, front wheel side	2			○
2	44311-NL9-810	Collar, front wheel side	2		○	
3	44311-NL9-910	Collar, front wheel side	2	○		
		Disc plate				
4	45250-NL9-910	Disc comp., front 320 x T6	2		○	○
5	45120-MFL-R10	Disc comp., R. front	1	○		
	45220-MFL-R10	Disc comp., L. front	1			
		Disc spacer				
6	45130-NLR-A30	Spacer, front wheel disc 0.2	2		○	
7	45130-NL9-000	Spacer, front wheel disc 1.5	2			○
		Axle				
8	44301-NL9-720	Axle, front wheel	1	○	○	
9	44301-NL6-000	Axle, front wheel	1			○
		Axle nut				
10	44303-NL9-720	Nut, front axle	1	○	○	
11	44303-NL6-000	Nut, front axle	1			○
		Nut				
12	90305-NL9-720	Nut, M30 x 1.0	1	○	○	
13	90305-NL6-000	Nut, M28 x 1.0	1			○
		Axle guide				
14	44304-NL9-000	Guide A, front axle	1			○
15	44305-NL9-000	Guide B, front axle	1			○
16	44304-NL9-720	Guide, front axle	1	○	○	
		Axle washer				
17	90535-NL9-720	Washer, axle	1	○	○	
18	90503-NL6-000	Washer, 45 x 22 x 3	1			○
		Guide washer				
19	44306-NL9-720	Guide washer, front axle	1	○	○	
		Fork side shim				
20	90525-NL9-720	Shim 0.2, front fork right side	N	○	○	
21	90526-NL9-720	Shim 0.3, front fork right side	N	○	○	
22	90525-NL9-000	Shim 0.2, front fork right side	N			○
23	90526-NL9-720	Shim 0.3, front fork right side	N			○

- When using the NL9 wheel with the standard fork, replace the brake disc with Brembo.
- Since the racing kit brake disc is thicker than the MFL standard disc, use racing kit discs for a racing circuit that requires higher brake performance.

Racing Kit

Front Axle Assembly (View from front)

Fork: MFL fork
 Wheel: NL9 kit or MFL Wheel
 Axle: NL9 kit

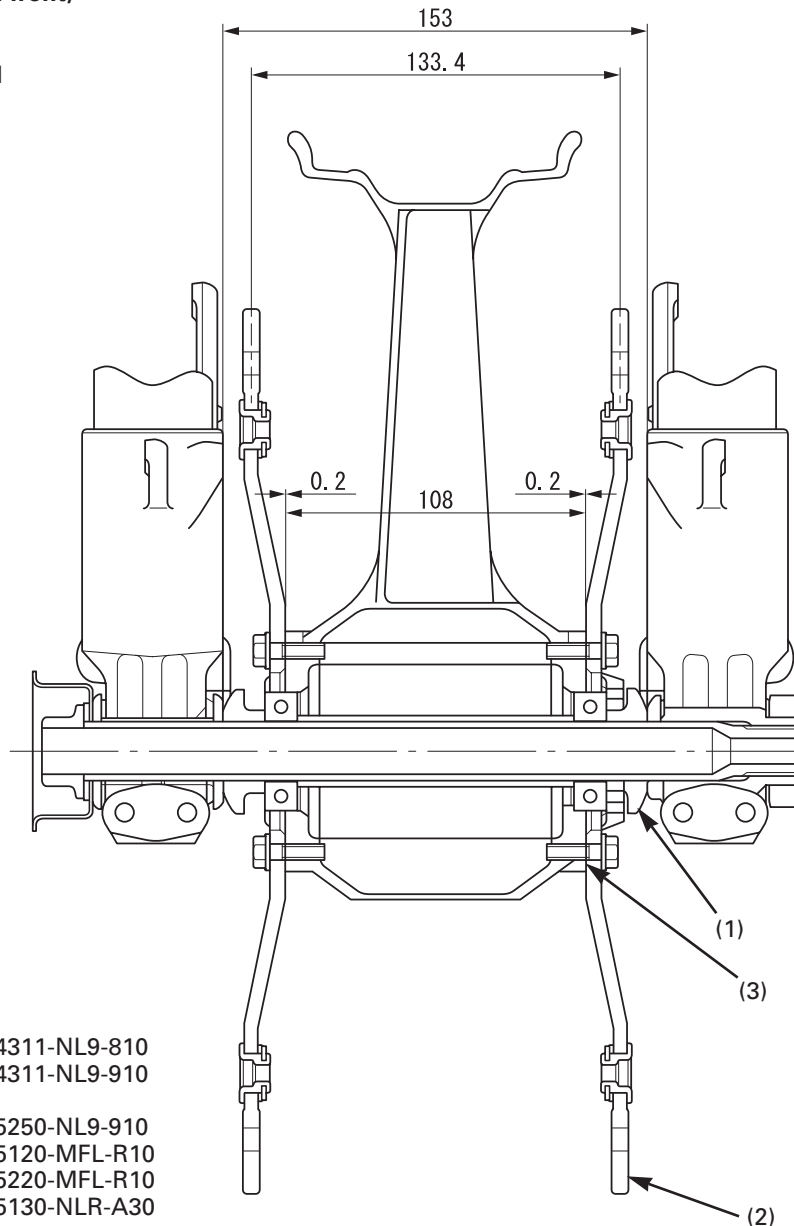

CBR1000RR Kit (NL9) Wheel

Wheel parts for MFL Fork

- | | |
|-----------------------------|---------------|
| (1) Front wheel side collar | |
| NL9 wheel: | 44311-NL9-810 |
| MFL wheel: | 44311-NL9-910 |
| (2) Disc plate | |
| NL9 wheel: | 45250-NL9-910 |
| MFL wheel: | 45120-MFL-R10 |
| (3) Disc spacer | 45220-MFL-R10 |
| | 45130-NLR-A30 |

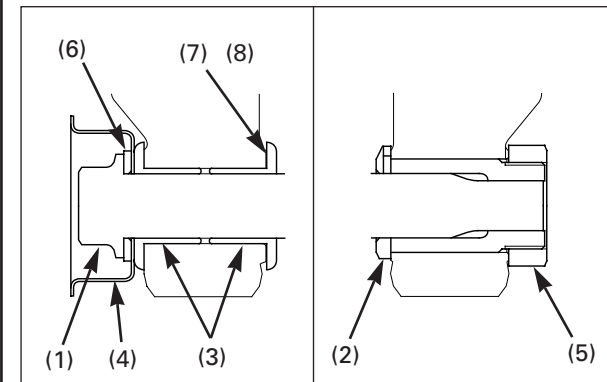

Axle parts for MEL fork

- | | |
|-----------------------------|---------------|
| (1) Front wheel axle | 44301-NL9-720 |
| (2) Front axle nut | 44303-NL9-720 |
| (3) Front axle guide | 44304-NL9-720 |
| (4) Front axle guide washer | 44306-NL9-720 |
| (5) Nut, M30 x 1.0 | 90305-NL9-720 |
| (6) Front axle washer | 90535-NL9-720 |
| (7) Fork R. side shim, 0.2 | 90525-NL9-720 |
| (8) Fork R. side shim, 0.3 | 90526-NL9-720 |

Front Axle Assembly (View from front)

Fork: Showa Special Fork
 Wheel: NL9 kit Wheel
 Axle: NL9 kit

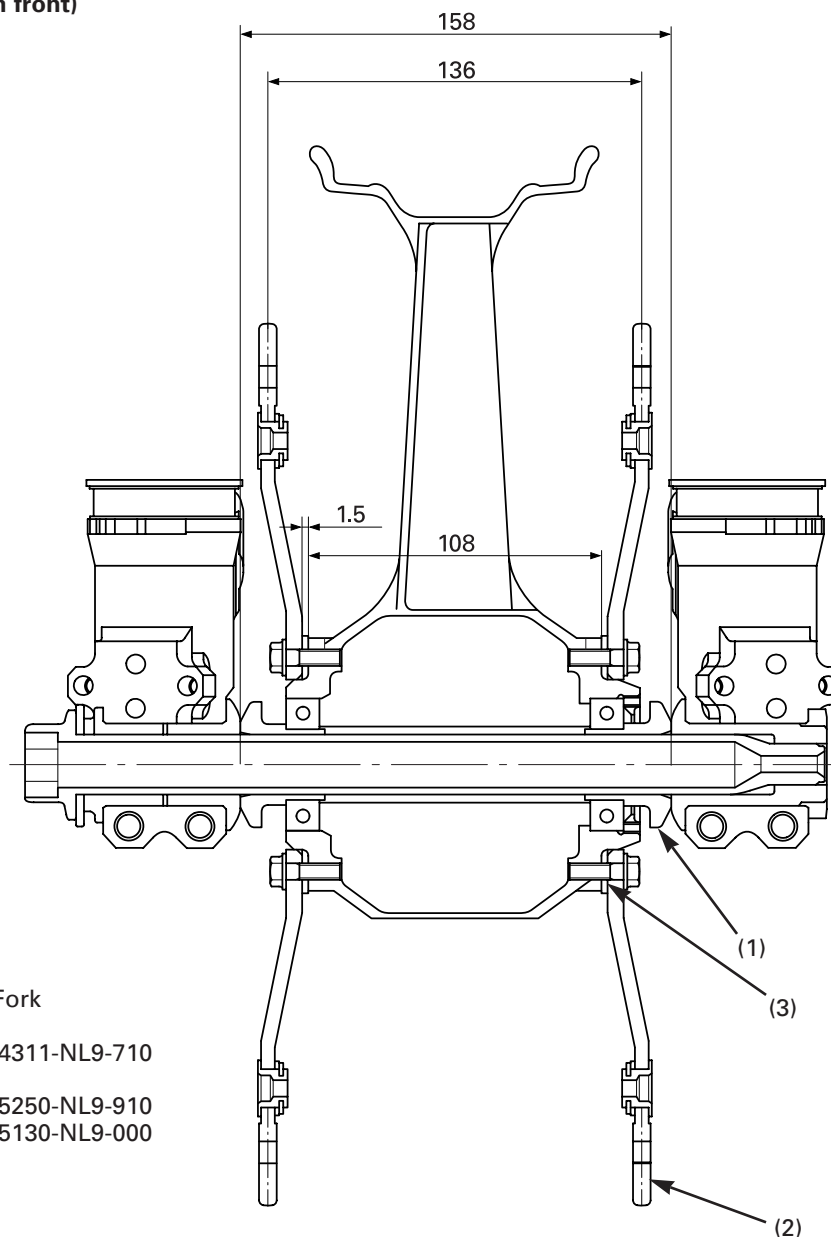

CBR1000RR Kit (NL9) Wheel

Wheel parts for Showa Special Fork

- (1) Front wheel side collar
 NL9 wheel: 44311-NL9-710
- (2) Disc plate
 NL9 wheel: 45250-NL9-910
- (3) Disc spacer
 NL9 wheel: 45130-NL9-000

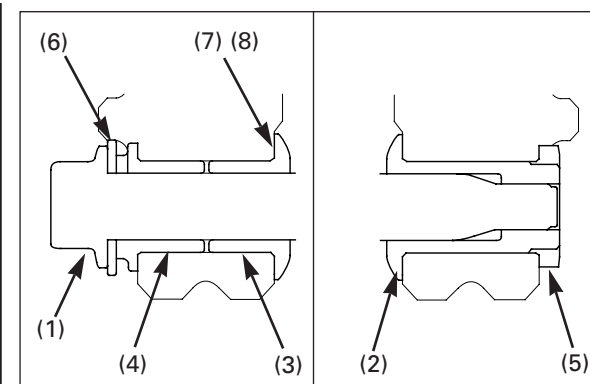

Axle parts for Showa Special Fork

- (1) Front wheel axle 44301-NL6-000
- (2) Front axle nut 44303-NL9-000
- (3) Front axle guide A 44304-NL9-000
- (4) Front axle guide B 44305-NL9-000
- (5) Nut, M28 x 1.0 90305-NL6-000
- (6) Washer, 45 x 22 x 3 90535-NL6-000
- (7) Fork side shim, 0.2 90525-NL9-000
- (8) Fork side shim, 0.3 90526-NL9-000

Racing Kit

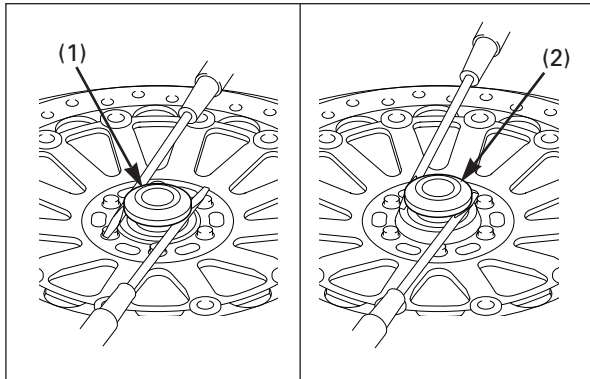

(1) RIGHT SIDE COLLAR
(2) LEFT SIDE COLLAR

Disassembly/Wheel Bearing Replacement

! WARNING

A contaminated brake disc or pad reduces stopping power, and can cause a serious injury or death.

Discard contaminated pads and clean a contaminated disc with a high quality brake degreasing agent.

Remove the right and left side collars using two screw drivers as shown.

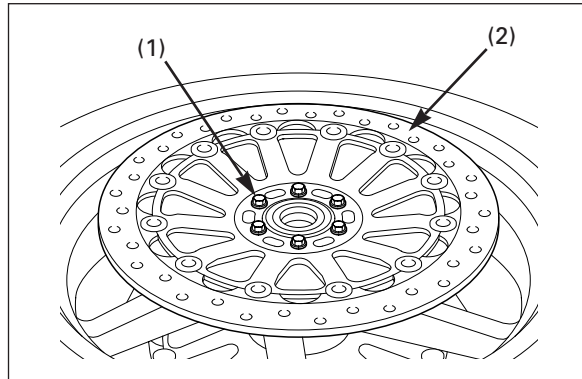

(1) BOLTS
(2) BRAKE DISC

Remove the bolts and brake discs.

Turn the inner race of each bearing with your finger. The bearings should turn smoothly and quietly. Also check that the bearing outer races fit tightly in the hub.

Remove and discard the bearings if the races do not turn smoothly, quietly, or if they fit loosely in the hub.

Replace the bearings in pairs.



(1) LOCK NUT WRENCH

Unstake the bearing retainer.
Remove the bearing retainer using a special tool.

Tool:

Lock nut wrench, 5.5 x 32/37 07716-0020203

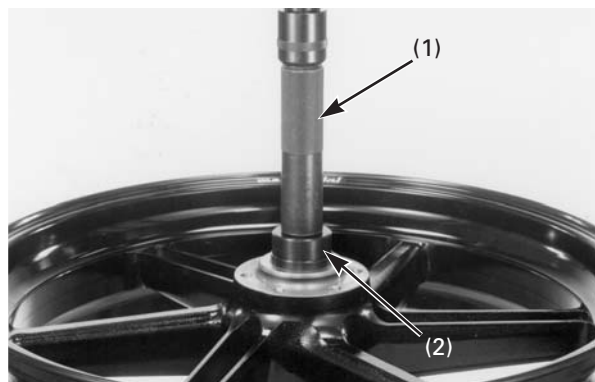

(1) DRIVER
(2) ATTACHMENT/PILOT

Press the right wheel bearing and distance collar using a special tools and a hydraulic press until the left wheel bearing is removed.

NOTICE

Pressing the right wheel bearing more than necessary may cause it to fall into the wheel hub.

Tools:
Driver 07749-0010000
Attachment, 42 x 47 mm 07746-0010300
Pilot, 25 mm 07746-0040600

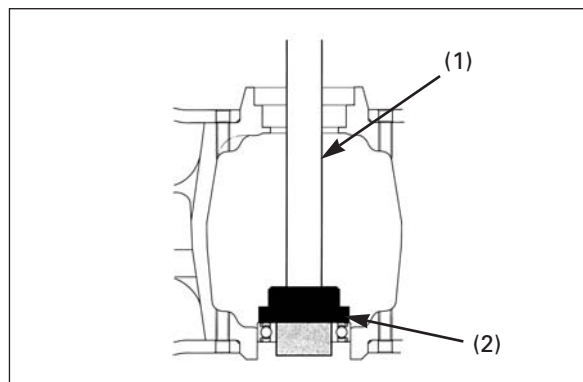

(1) DRIVER
(2) ATTACHMENT/PILOT

Remove the right side bearing using the special tools.

Tools:
Driver 07749-0010000
Attachment, 42 x 47 mm 07746-0010300
Pilot, 25 mm 07746-0040600

Never install old bearings; once bearings have been removed, they must be replaced with new ones. Replace the wheel bearings in pairs.

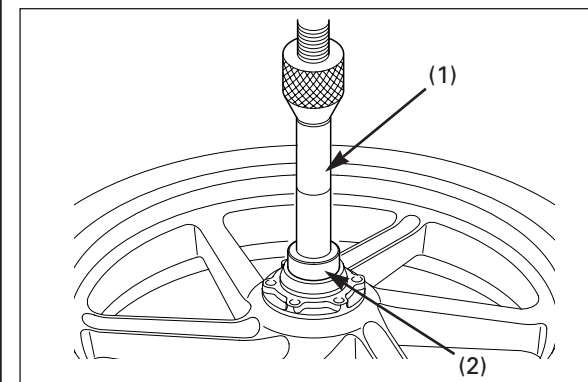

(1) DRIVER
(2) ATTACHMENT/PILOT

Assembly

Apply oil to the bearing outer surface. Drive the new left wheel bearing into the hub until it seats, using a special tools and a hydraulic press.

Tools:
Driver 07749-0010000
Attachment, 42 x 47 mm 07746-0010300
Pilot, 25 mm 07746-0040600

Press the bearing with 3 tons pressure.
Hydraulic press pressure: 29.4 kN (3,000 kgf)
Gauge reading pressure: 29.4 ÷ (press piston area) kN/mm²

Racing Kit

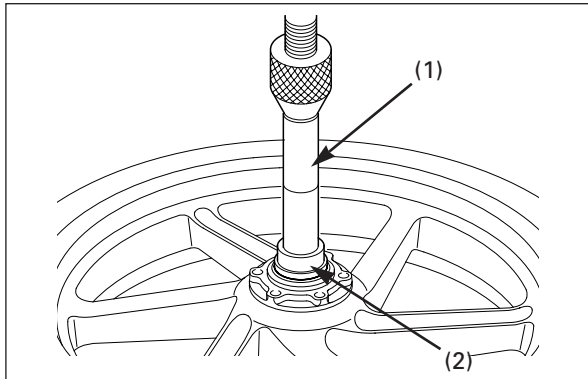

(1) DRIVER
(2) ATTACHMENT/PILOT

Install the distance collar, then drive the right side bearing into the hub using the same tools.

Tools:

Driver	07749-0010000
Attachment, 42 x 47 mm	07746-0010300
Pilot, 25 mm	07746-0040600

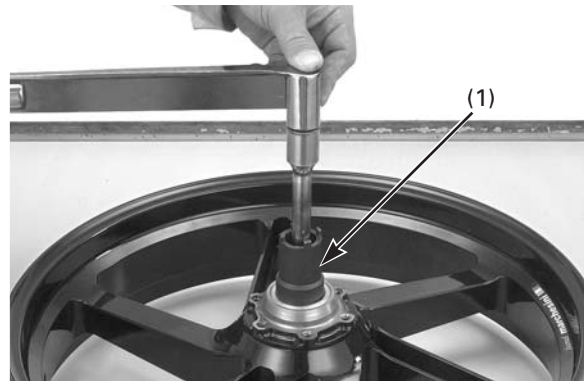

(1) LOCK NUT WRENCH

Apply molybdenum disulfide grease to the new bearing retainer threads and install it into the hub. Tighten the bearing retainer using the special tools.

Tool:

Lock nut wrench, 5.5 x 32/37	07716-0020203
------------------------------	---------------

Torque: 39 N·m (4.0 kgf·m, 29 lbf·ft)

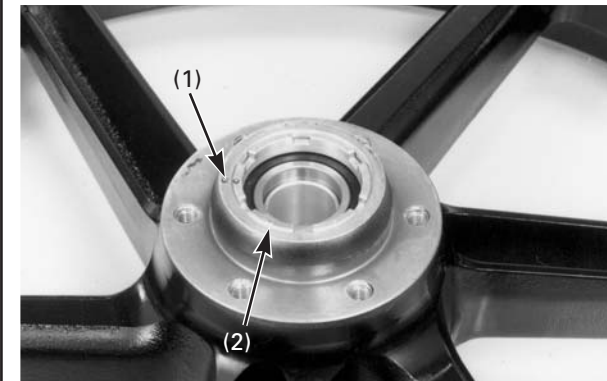

(1) BEARING RETAINER
(2) PUNCH

Secure the bearing retainer with a punch.

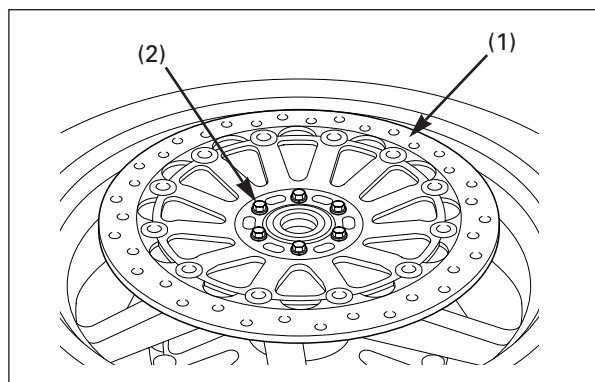

(1) BRAKE DISC
(2) BOLTS

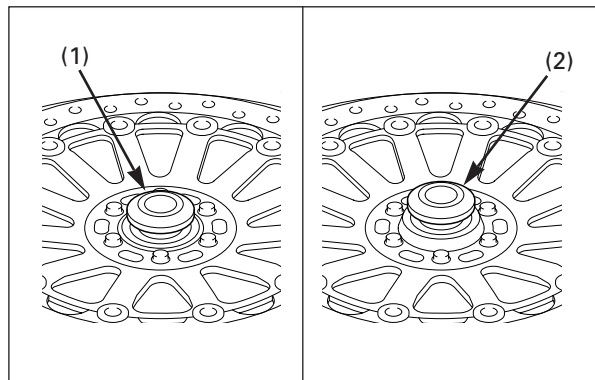

(1) RIGHT SIDE COLLAR
(2) LEFT SIDE COLLAR

Install the brake discs and tighten the bolts to the specified torque.

Torque: 15 N•m (1.5 kgf•m, 11 lbf•ft)

Install the wheel side collars.

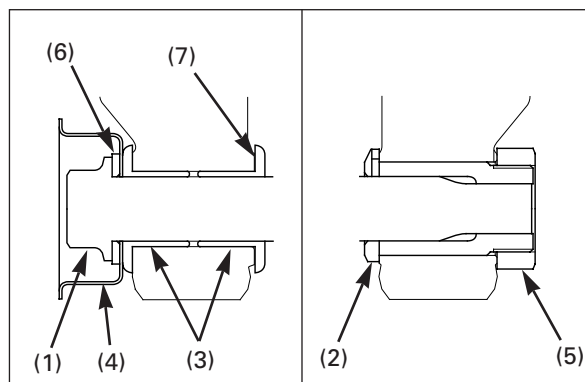

(1) AXLE (2) AXLE NUT (3) AXLE GUIDE
(4) AXLE GUIDE WASHER (5) SIDE NUT
(6) AXLE WASHER (7) SHIM (S)

Standard Fork:

If the wheel, fork leg, and/or distance collar have been replaced, adjust the axle distance as follows:

1. Apply molybdenum disulfide grease to the axle nut and axle side nut threads. Install the front axle nut into the left fork axle from the inside, install and tighten the axle side nut to the specified torque.

Torque: 78 N•m (8.0 kgf•m, 58 lbf•ft)

2. Install the front axle guide into the right fork axle.
3. Temporarily install the front wheel between the fork legs and then install the front axle and axle washer but do not tighten.
4. With the front brake applied, pump the fork up and down several times to parallel the fork.
5. Measure the clearance between the right wheel side collar and axle guide.
6. Adjust the clearance by inserting shim(s) between the right fork axle holder and axle guide. Make sure there is no clearance.
7. Tighten the axle holder bolts to the specified torque.

Torque: 22 N•m (2.2 kgf•m, 16 lbf•ft)

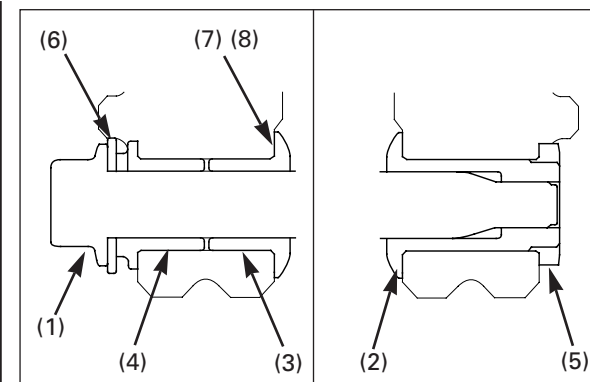

(1) AXLE (2) AXLE NUT (3) AXLE GUIDE A
(4) AXLE GUIDE B (5) SIDE NUT
(6) AXLE WASHER (7) SHIM (S)

Showa Special Fork:

If the wheel, fork leg, and/or distance collar have been replaced, adjust the axle distance as follows:

1. Apply molybdenum disulfide grease to the axle nut and axle side nut threads. Install the front axle nut into the left fork axle from the inside, install and tighten the axle side nut to the specified torque.

Torque: 78 N•m (8.0 kgf•m, 58 lbf•ft)

2. Install the front axle guide A and B into the right fork axle.
3. Temporarily install the front wheel between the fork legs and then install the front axle and axle washer but do not tighten.
4. With the front brake applied, pump the fork up and down several times to parallel the fork.
5. Measure the clearance between the right wheel side collar and axle guide A.
6. Adjust the clearance by inserting shim(s) between the right fork axle holder and axle guide A. Make sure there is no clearance.
7. Tighten the axle holder bolts to the specified torque.

Torque: 22 N•m (2.2 kgf•m, 16 lbf•ft)

Racing Kit

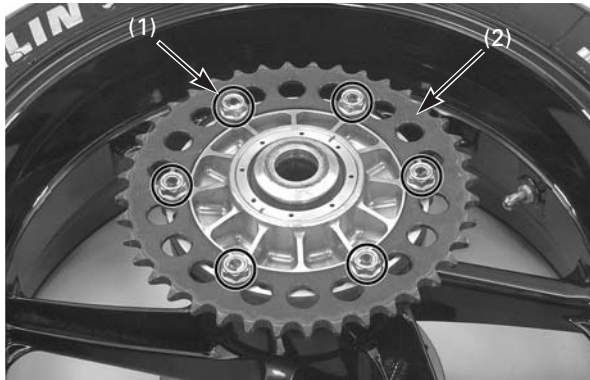

(1) NUTS
(2) DRIVEN SPROCKET

Optional Rear Wheel

Disassembly

If you will replace the driven sprocket, loosen the driven sprocket nuts.

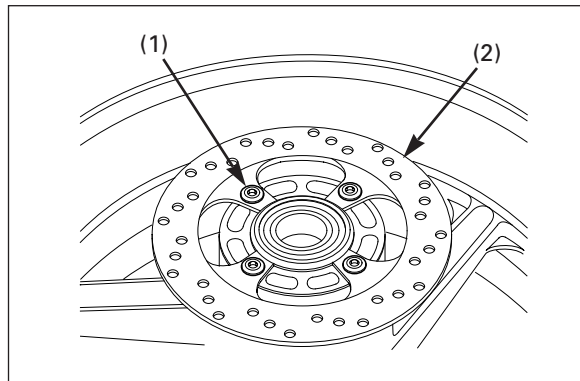

(1) BOLTS (2) BRAKE DISC

Remove the bolts and brake disc.



(1) DRIVEN FLANGE



(1) DAMPER RUBBERS

Remove the final driven flange assembly from the left wheel hub.

Remove the damper rubbers.

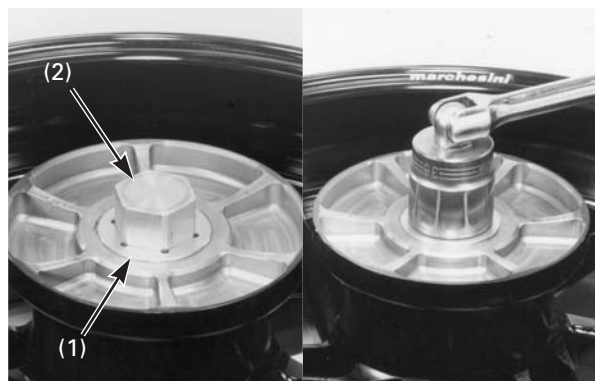

(1) BEARING RETAINER
(2) RETAINER TOOL

Wheel Bearing Replacement

Remove the wheel bearing retainer using the special tool.

The wheel bearing retainer has left hand threads.

Tool:

Retainer tool

87000-NL6-000

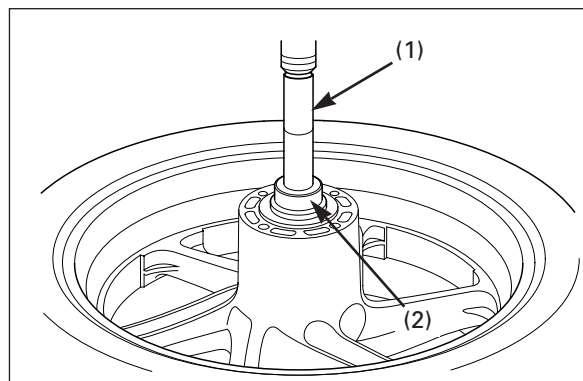

(1) DRIVER
(2) ATTACHMENT/PILOT

Press the right wheel bearing and distance collar using a special tools and a hydraulic press until the left wheel bearing is removed.

NOTICE

Pressing the right wheel bearing more than necessary may cause it to fall into the wheel hub.

Tools:

Driver
Attachment, 52 mm
Pilot, 25 mm

07749-0010000
07946-3710200
07746-0040600

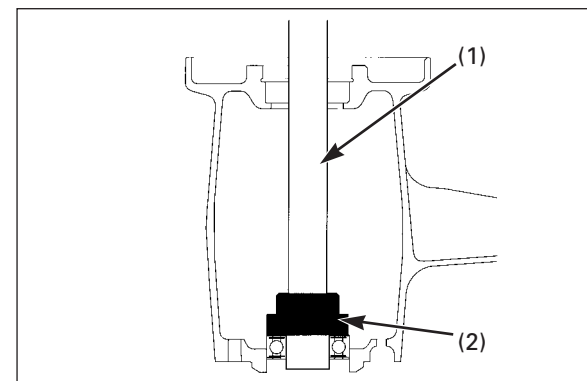

(1) DRIVER
(2) ATTACHMENT/PILOT

Remove the right side bearing using the special tools.

Tools:

Driver
Attachment, 52 mm
Pilot, 25 mm

07749-3710001
07946-3710200
07746-0040600

Never install old bearings; once the bearing have been removed, they must be replaced with new ones.

Replace the wheel bearings in pairs.

Racing Kit

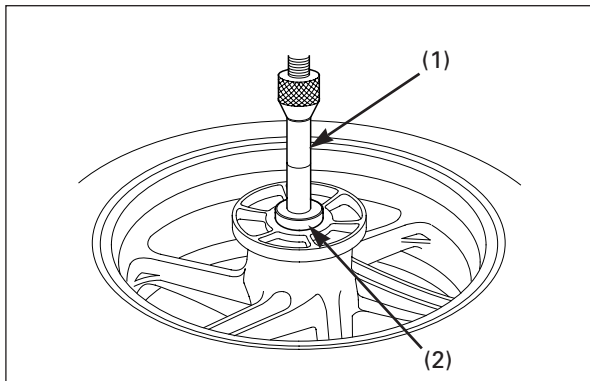

(1) DRIVER
(2) ATTACHMENT/PILOT

Assembly

Apply oil to the bearing outer surface.
Drive the new left wheel bearing into the hub until it seats.

Tools:
Driver 07749-0010000
Attachment, 52 mm 07946-3710200
Pilot, 25 mm 07746-0040600

Press the bearing with 3 tons pressure.
Hydraulic press pressure:
 29.4 kN (3,000 kgf)
Gauge reading pressure:
 $29.4 \div (\text{press piston area}) \text{ kN/mm}^2$

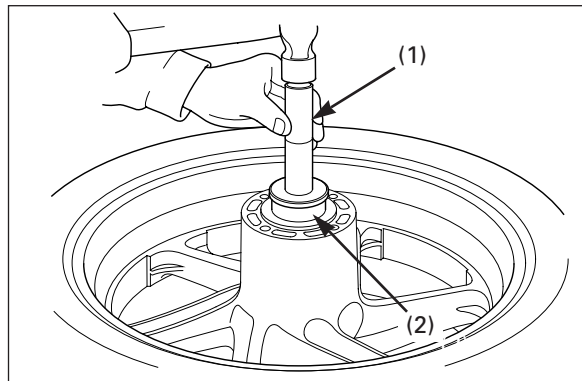

(1) DRIVER
(2) ATTACHMENT/PILOT

Install the distance collar, then drive the right side bearing into the hub using the same tools.

Tools:
Driver 07749-0010000
Attachment, 52 mm 07946-3710200
Pilot, 25 mm 07746-0040600

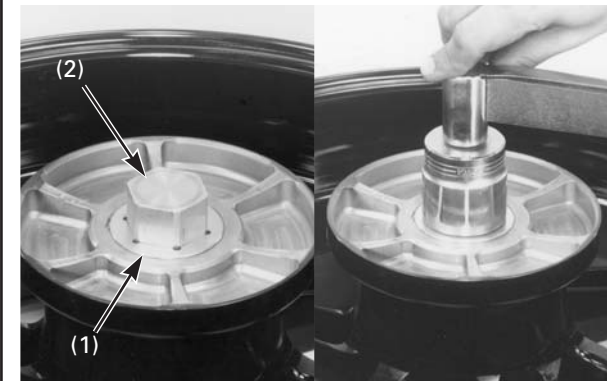

(1) BEARING RETAINER
(2) RETAINER TOOL

Apply a locking agent to the bearing retainer threads and install it into the hub.
The bearing retainer has left hand threads.

Tighten the bearing retainer to the specified torque.

Tool:
Retainer tool 87000-NL6-000

Torque: 98 N·m (10.0 kgf·m, 72 lbf·ft)

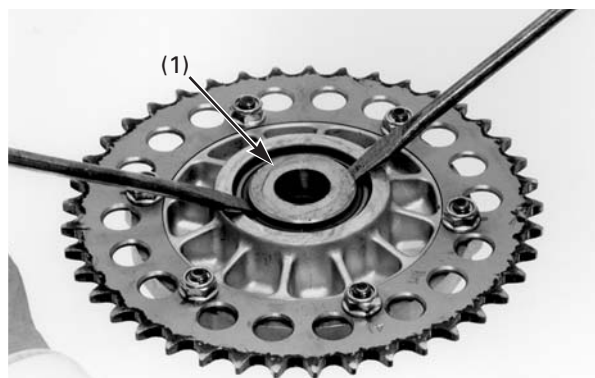

(1) LEFT SIDE COLLAR



(1) CIRCLIP

Driven flange bearing replacement

Remove the driven flange left side collar using two screwdrivers as shown.

Remove the circlip from the drive flange.

Drive out the driven flange bearing and right side collar as an assembly from the driven flange.

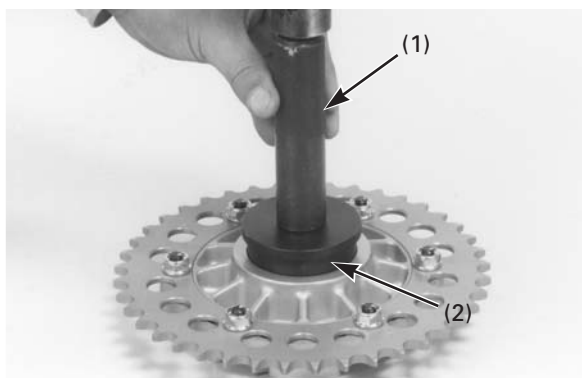

(1) DRIVER
(2) ATTACHMENT/PILOT

Drive the new driven flange bearing into the driven flange until it seat using the special tools. Never install old bearings; once the bearing have been removed, they must be replaced with new ones.

Tools:

Driver
Attachment, 62 x 68 mm
Pilot, 25 mm

07749-0010000
07746-0010500
07746-0040600



(1) RIGHT SIDE COLLAR

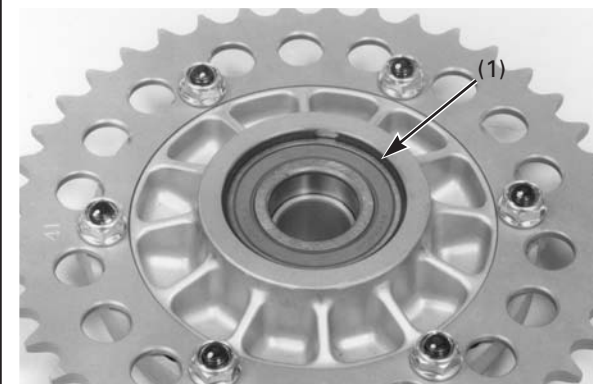

(1) CIRCLIP

Install the driven flange right side collar.

Install the circlip into the groove securely.

Racing Kit

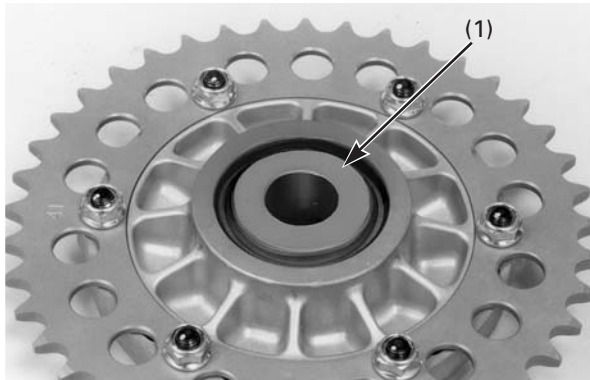

(1) LEFT SIDE COLLAR

Install the driven flange left side collar.

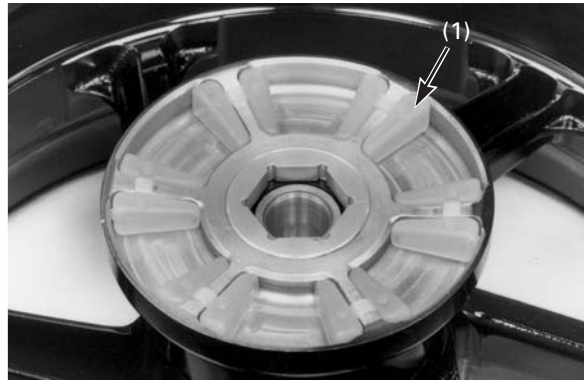

(1) DAMPER RUBBERS

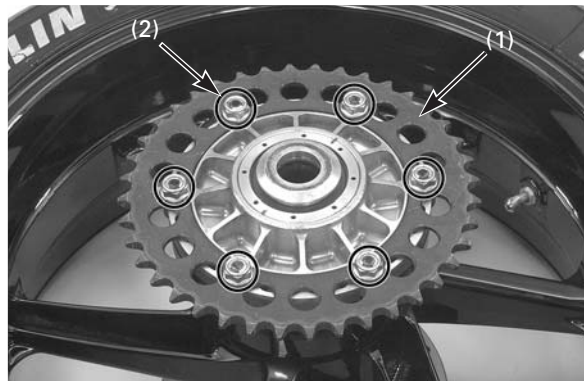

(1) DRIVEN SPROCKET
(2) NUTS

Install the damper rubbers into the left wheel hub.
Install the final driven flange assembly onto the left wheel hub.
If the driven sprocket is removed, apply oil (Elf XT3818) to the driven flange nut threads and seating surfaces.
Tighten the driven sprocket nuts to the specified torque.

Torque: 34 N·m (3.5 kgf·m, 25 lbf·ft)

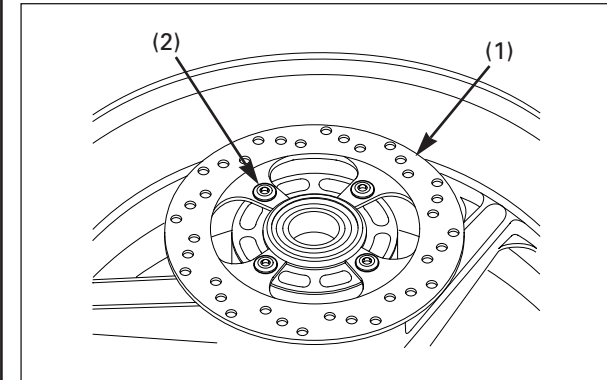

(1) BRAKE DISC (2) BOLTS

Install the brake disc onto the right wheel hub.
Note the direction of the brake disc.

Apply a locking agent to the brake disc bolt threads.
Install the brake disc and tighten the bolts to the specified torque.

Torque: 16 N·m (1.6 kgf·m, 12 lbf·ft)

Install the right side collar.

When using the racing kit rear wheel with the standard swingarm, the grind-off the brake caliper bracket guide bosses from the swingarm.

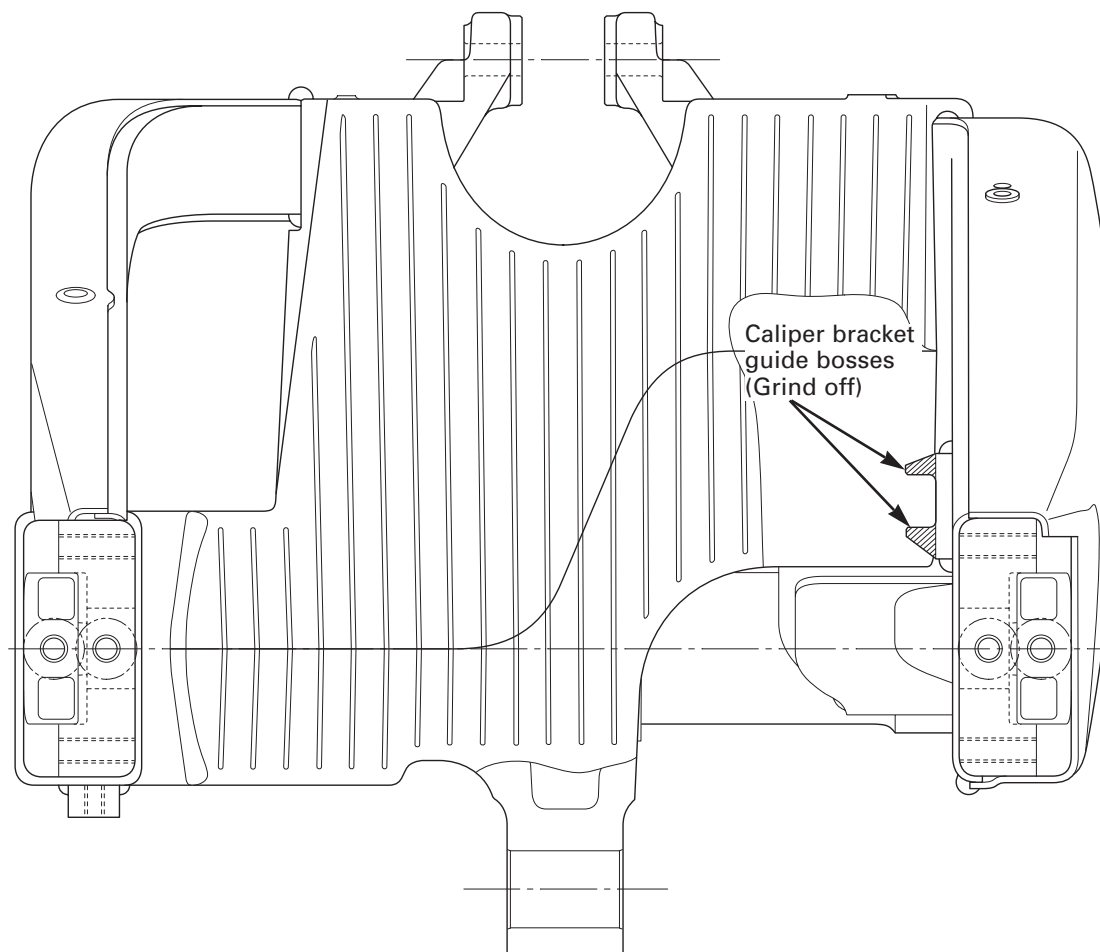

Racing Kit

Rear Axle Illustration (view from rearward)

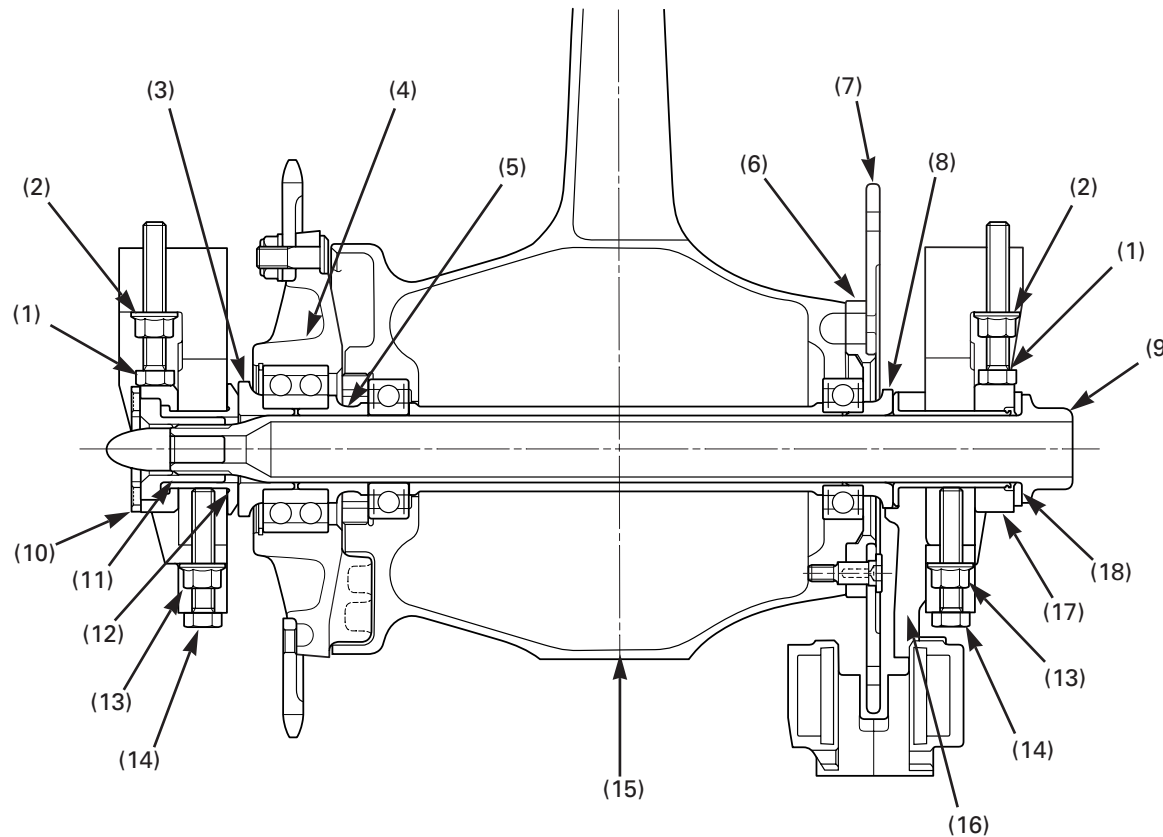

- (1) DRIVE CHAIN ADJUSTING BOLT
- (2) DRIVE CHAIN ADJUSTING BOLT LOCK NUT
- (3) DRIVEN FLANGE LEFT SIDE COLLAR
- (4) DRIVEN FLANGE
- (5) DRIVEN FLANGE RIGHT SIDE COLLAR
- (6) BRAKE DISC SPACER
- (7) BRAKE DISC
- (8) REAR AXLE RIGHT SIDE COLLAR
- (9) REAR AXLE

- (10) LEFT DRIVE CHAIN ADJUSTING PLATE
- (11) REAR AXLE NUT
- (12) REAR AXLE LEFT SIDE COLLAR
- (13) STOPPER BOLT LOCK NUT
- (14) STOPPER BOLT
- (15) REAR WHEEL
- (16) REAR BRAKE CALIPER BRACKET
- (17) RIGHT DRIVE CHAIN ADJUSTING PLATE
- (18) WASHER

Installation

Install the rear wheel as follows:

1. Install the rear wheel into the swingarm and temporarily install the each parts.
 2. Adjust the drive chain free play by turning the drive chain adjusting bolts (1).
Make sure the axle is installed smoothly.
 3. Temporarily tighten the rear axle.
 4. Secure the lock chain adjusting bolts by tightening the lock nuts (2).
 5. Hand tighten the stopper bolts (14) until the screws just touch the rear axle left side collar (12) and right rear axle side collar (8).
- Note that the axle side collars are tilt when tightening the the stopper bolts.
6. Secure the stopper bolts by tightening the lock nuts (13).
 7. Loosen the rear axle and check that there are no free play on the adjusting plates (10, 17).
 8. Make sure the axle is installed smoothly without stress.
 9. Tighten the rear axle to the specified torque.

NOTICE

- Do not pull the rear wheel applying external force by installing a T wrench between the drive chain and driven sprocket while tightening the rear axle. The alignment of a rear wheel may not coming out and the axle's actual torque is lowered by the friction of the axle.
- Make sure the rear axle threads are seated to the axle nut threads before tightening the axle using impact wrench.

Front Wheel Speed Sensor Installation

Remove the front wheel and then remove the right brake disc bolt. Install the front wheel pulser onto the right brake disc, then reinstall and tighten the brake disc bolts.

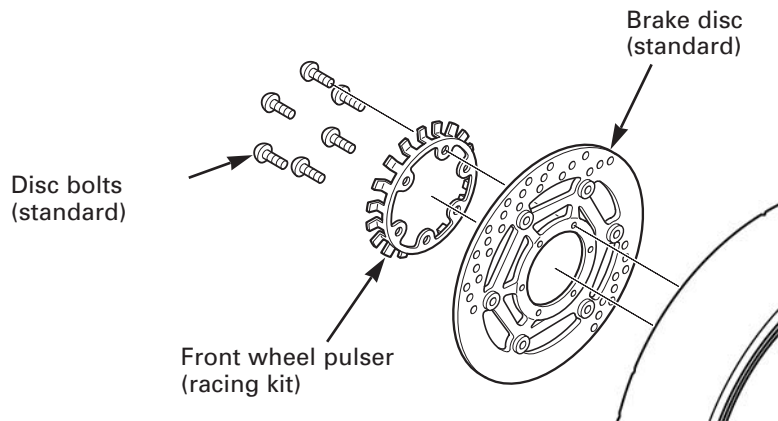

Remove the right axle pinch bolts from the right fork leg, then install the VFW sensor stay, then reinstall the pinch bolts.

Reinstall the front wheel. Install the front wheel speed sensor onto the bracket and tighten the bolt. Connect the sensor sub-cord connector to the sensor.

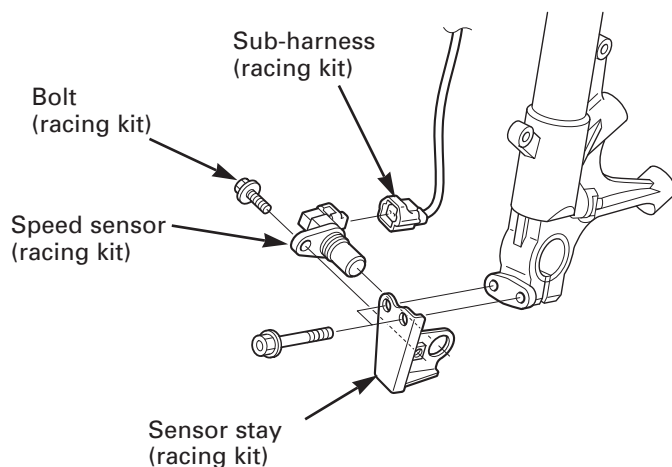

Route the speed sensor wire properly, connect the 3P (Black) connector to the main wire harness near the front upper cowl stay.

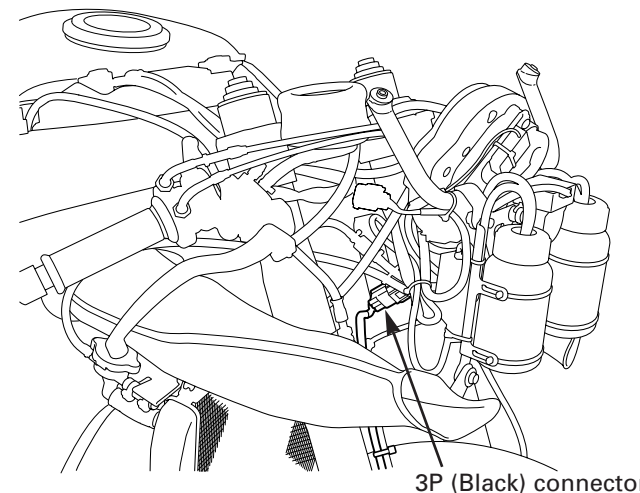

Check for clearance between the wheel speed sensor tip and wheel pulser.

Clearance: 1.5 – 2.0 mm (0.06 – 0.08 in)

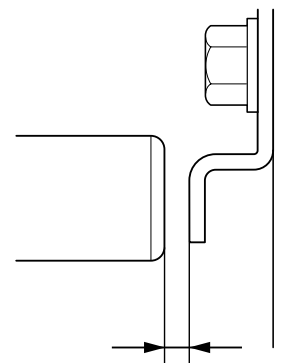

Racing Kit

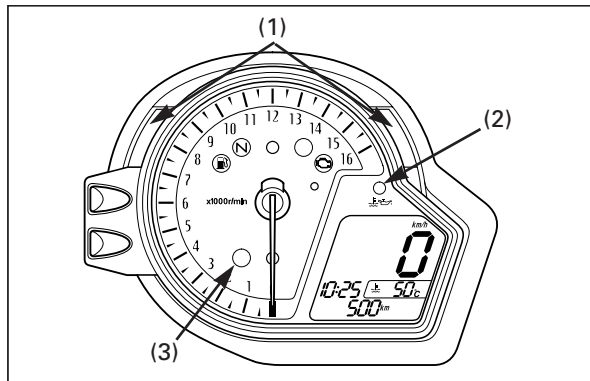

- (1) SHIFT-UP INDICATOR
- (2) TEMPERATURE/OIL INDICATOR
- (3) PIT LOAD SPEED LIMIT INDICATOR

Combination Meter Function

The racing kit combination meter has the following functions:

- Lap time recording and indication
- Coolant temperature indication and maximum temperature recording
- Temperature/oil/HESD warning indication
- Fuel pulse indication

Shift-up Indicator

When the engine revs exceed the setting value, the shift-up indicator illuminates or flashes. The shift-up indicator can be set in range between 2,000 – 16,000 min⁻¹ (rpm).

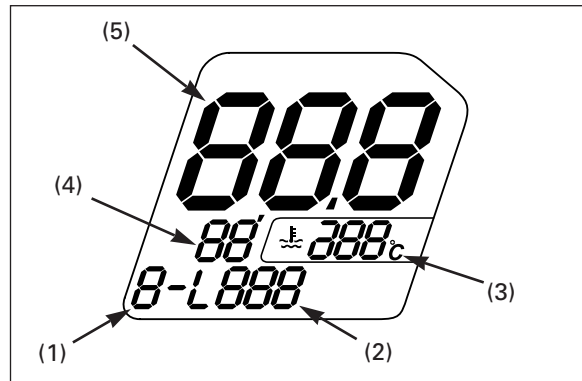

- (1) SESSION NUMBER (2) LAP NUMBER
- (3) COOLANT TEMPERATURE
- (4) LAP TIME (MIN.) (5) LAP TIME (SEC.)

Lap Time Indicator

GO mode:

When the engine stop switch is set on RUN, the combination meter is in the "STOP" mode. When the combination meter receives the LAP marker signal (when the passing switch is pressed) or when engine revs exceed 5,000 min⁻¹ (rpm), the lap time indicator system enters the "GO" mode. In the "GO" mode, the combination meter indicate and records the session number, lap number, each lap time and coolant temperature (real time indication). The combination meter records the maximum coolant temperature in each lap.

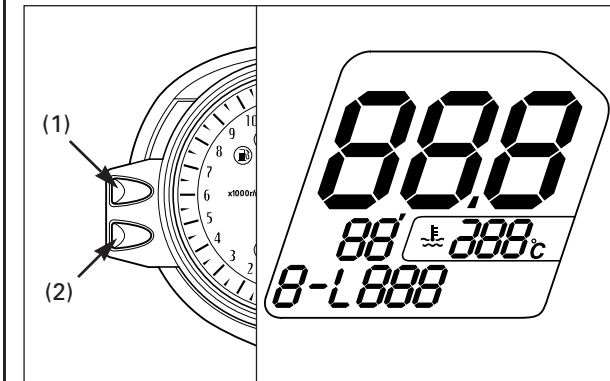

- (1) "A" BUTTON
- (2) "B" BUTTON
- (3) COOLANT TEMPERATURE INDICATION

During "GO" mode, the coolant temperature indication shows real time temperature.

The coolant temperature can be indicated between 35 – 132°C (95 – 270°F). The temperature lower than 35°C (95°F), the indication is "--". The temperature more than 132°C (270°F), the maximum temperature stays and blinking.

When the lap count is entered, indicate previous lap's maximum temperature about 5 seconds, then return to the real time indication.

Temperature indication change:

1. Turn the engine stop switch RUN while pressing the "B" button.
The temperature unit starts blinking and change mode.
2. Change unit by pressing the "A" button.
3. After determine you wish to indicate, press "B" button.

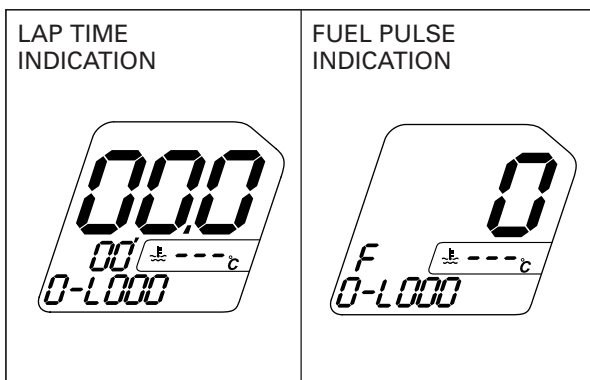

Lap Time Data Reading

The lap data can be stored up to 199 laps. When the stored data exceeds 199 laps, the oldest data is overwritten by the current lap data.

STOP mode:

If you wish to read out data for each lap, make sure the combination meter is in "STOP" mode by pressing the "A" button.

When the engine stop switch is set on RUN or the "A" button is pressed under the "GO" mode, the combination meter enters the "STOP" mode.

The stored lap data and fuel pulse can be read out in this mode.

The indication can be changed by pressing the "A" and "B" button simultaneously.

Stored lap data is displayed from lap 1 to the latest lap by pushing the 'RESET' button.

When the "A" button is pressed, the next stored data is displayed.

When the "B" button is pressed, the previous stored data is displayed.

If the "A" or "B" button is pressed and held, the lap time data will be advanced or returned.

When you wish to reset the lap data, press both the "A" and "B" buttons simultaneously for more than two seconds.

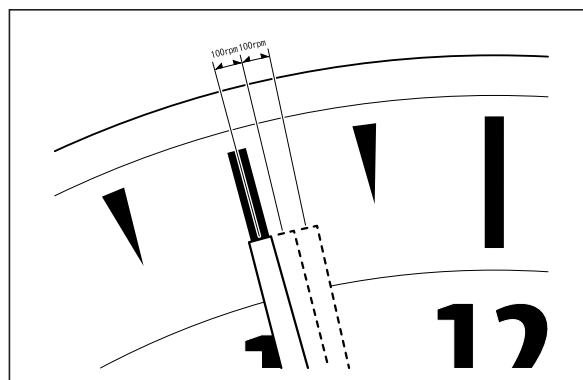

How to set the shift-up indicator

1. Turn the engine stop switch to RUN while pressing the "A" button until the combination meter initial action finishes. The needle indicates the current setting.
2. Align the needle to the desired rpm by pressing the "B" button. Each time the button is pressed, the needle setting increases 100 min⁻¹ (rpm). Press and hold the button for more than one second to increase the setting 1,000 min⁻¹ (rpm). If the maximum setting value (16,000 min⁻¹ (rpm)) is exceeded, the needle returns to 2,000 min⁻¹ (rpm). After determine the illuminating rev., press the "A" button.

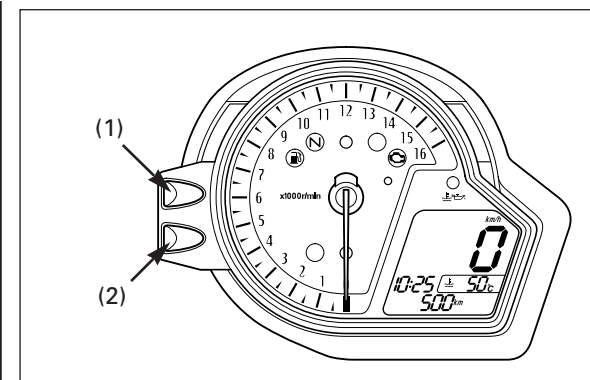

(1) "A" BUTTON
(2) "B" BUTTON

3. Press the "B" button and select a illuminating or flashing pattern.
 - Illuminating pattern and brightness (3 patterns)
 - Flashing pattern and brightness (6 patterns)
4. After the shift-up indicator setting is finished, press the "B" button. The combination meter returns to its normal indication mode (the tachometer needle returns to 0).

When the tachometer or speedometer input signal is detected, or not accessed for more than 30 seconds during setting, the setting value is cancelled and returns to the normal indication mode.

Racing Kit

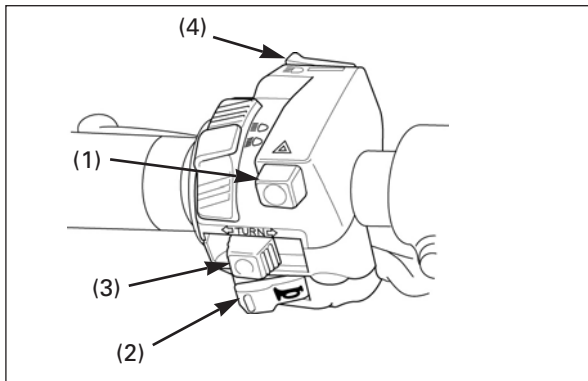

- (1) HAZARD SWITCH (MODE SWITCH)
- (2) HORN SWITCH (POWER SHIFTER)
- (3) TURN SIGNAL SWITCH (PIT ROAD SPEED LIMIT)
- (4) PASSING SWITCH (STOP WATCH)

Left Handlebar Switch Function

On the racing kit, the switches on the left handlebar function as follows:

- Hazard switch: Mode switch function
- Horn switch: Power shifter function
- Turn signal switch: Pit road speed limiter
- Passing switch: Stop watch function (lap time)

Mode Switch:

When the hazard switch is OFF, the ECU setting is in Mode 1 and the switch is ON in Mode 2. The mode actually changes after the first gear change is done while running.

Quick Shift Switch:

Pushing the switch activates both the ignition and fuel injection cut-off systems.

Pit Load Speed Limiter:

While pushing the turn signal switch to the right, the pit road speed limiter is activated. The pit road speed limiter is deactivated when you turn the turn signal switch off.

Stop Watch:

When the switch is pushed, the stop watch is started.

See PGM-FI Setting manual for setting.

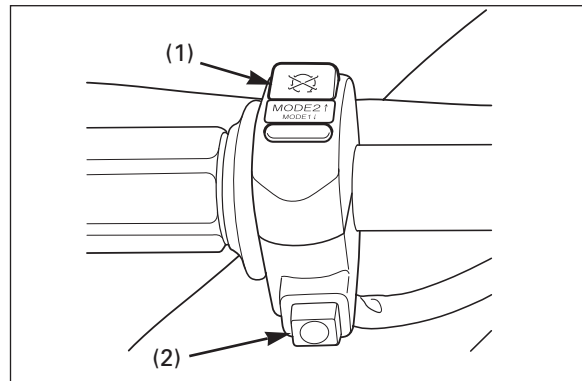

- (1) MODE SWITCH
- (2) PIT ROAD SPEED LIMIT SWITCH

Mode Switch

On the racing kit optional mode switch, the switch-function as follows:

Mode switch:

When you push the switch to rearward, ECU setting is in Mode 1, and you push the switch forward, ECU setting is in Mode 2.

The mode actually changes after the first gear change is done while running.

Pit road speed limit switch:

While pushing the switch, the pit road speed limiter is activated.

The pit road speed limiter is deactivated when you release the switch.

See PGM-FI Setting manual for setting.